



MADE IN ITALY



GENERAL CATALOG

CATALOGO GENERALE | CATALOGUE GENERAL

ALLGEMEINER KATALOG | общий каталог

21



A range of over
100 models



MADE IN ITALY





Quality since 1979

 **Aceti Macchine** progetta e produce macchine per la lavorazione e la finitura del metallo.

L'esperienza e le conoscenze del settore sviluppate con decenni di attività e con migliaia di macchine vendute, le permette di proporsi sul mercato europeo e mondiale come leader del settore.

Dal **1979** ad oggi vanta una vasta gamma con **oltre 100 modelli** tra cui: satinatrici, levigatrici per incavi, sbavalamiere, sbavatubi, smussatrici, levigatrici a nastro e a disco, pulitrici, smerigliatrici a mola, affilapunte, affilafrese, affilautensili, aspiratori per polveri. Tutti i modelli sono **prodotti interamente in Italia** presso il moderno stabilimento di Bolgare (Bergamo) nel cuore industriale della Lombardia. L'azienda è situata su un'area di 25.000 m² di cui 5.000 m² coperti adibiti alla progettazione, costruzione, assemblaggio, collaudo, vendita e assistenza.

 **Aceti Macchine** designs and manufactures machinery for metal processing and finishing.

Experience and knowledge developed over decades with the sale of thousands of machines positions the company as a leader in its sector both in Europe and around the world.

Since **1979 over 100 models** have been produced, including belt grinding machines for satin finishing, pipe notcher, deburring machines for metal sheets and tubes, bevelling machines, belt and disc grinding machines, polishing and buffing machines, grinding machines, drill sharpening machines, end mill sharpening machines, tool sharpening machines and dust extractors. All our products are **made entirely in Italy** at our modern premises in Bolgare (Bergamo), in the industrial heart of Lombardy. The company is located over an area of 25,000 square meters, including 5,000 sq.m. of covered space dedicated to design, manufacture, assembly, testing, sales and customer services.

 **Aceti Macchine** conçoit et produit des machines pour l'usinage et la finition du métal.

L'expérience et les connaissances du secteur développées au cours de dizaines d'années d'activité et avec des milliers de machines vendues lui permettent d'occuper la place de leader du secteur sur le marché européen et mondial.

Depuis **1979** jusqu'à aujourd'hui, elle se vante d'une large gamme avec **plus de 100 modèles** dont: machines à satiner, grugeuses de tubes, ébavureuses de tôles, ébavureuses de tubes, chanfreineuses, ponceuses à bande et à disque, polisseuses, tourets à meuler, affûteuses de forets, affûteuses de fraises, affûteuses d'outils, aspirateurs. Tous les modèles sont **entièrement produits en Italie** à l'usine moderne de Bolgare (Bergame) dans le cœur industriel de la Lombardie. L'entreprise se situe sur une zone de 25.000 m² dont 5.000 m² couverts destinés à la conception, à la fabrication, à l'assemblage, au test, à la vente et à l'assistance.

 **Aceti Macchine** entwickelt und produziert Maschinen zur Bearbeitung und Feinbearbeitung von Metall.

Dank der langjährigen Erfahrung, der Kenntnis der Branche und tausender verkaufter Maschinen konnte man sich als führendes Unternehmen auf dem europäischen, wie auch auf dem weltweiten Markt behaupten. Ab **1979** bis heute mit einer Produktpalette mit **über 100 Modellen**, wie: Satiniermaschinen, Rohrausschleifmaschinen, Blechentgratmaschinen, Rohrentgratmaschinen, Kantenfräsmaschinen, Band- und Tellerschleifmaschinen, Poliermaschinen, Scheibenschleifmaschinen, Bohrer- und Fräuserschleifmaschinen, Werkzeugschleifmaschinen, Staub-Absauganlagen. Alle Modelle werden **vollständig in Italien**, in dem hochmodernen Werk in Bolgare (Bergamo), dem industriellen Herzstück der Lombardei, gefertigt. Das Firmenareal ist 25.000 m² groß, 5.000 m² sind für die Entwicklung, die Fertigung, den Zusammenbau, Abnahme, Verkauf und den Kundendienst bestimmt.

ART.	PAG.	ART.	PAG.	ART.	PAG.
ART. 01	24	ART. 59	36	ART. 106	50
ART. 02	25	ART. 60	18	ART. 107	50
ART. 03	25	ART. 61	26	ART. 108	50
ART. 04	25	ART. 62	37	ART. 109	50
ART. 05	32	ART. 63	31	ART. 110	50
ART. 06	32	ART. 64	36	ART. 112	53
ART. 07	31	ART. 65	16	ART. 113	51
ART. 08	32	ART. 66	45	ART. 114	53
ART. 15	27	ART. 67	34	ART. 115	53
ART. 16	31	ART. 68	41	ART. 119	51
ART. 17	31	ART. 70	44	ART. 127	32
ART. 19	27	ART. 71	46	ART. 128	42
ART. 21	38	ART. 72	44	ART. 129	42
ART. 22	30	ART. 73 N	35	ART. 130	20
ART. 23	40	ART. 74	45	ART. 131	33
ART. 24	37	ART. 76	6	ART. 132	49
ART. 26	39	ART. 78	16	ART. 133	49
ART. 27	45	ART. 81	21	ART. 134	49
ART. 28	41	ART. 82	29	ART. 135	30
ART. 29	41	ART. 83	26	ART. 136	29
ART. 30	39	ART. 84	28	ART. 139	48
ART. 31	39	ART. 85	27	ART. 140	48
ART. 32	40	ART. 86	29	ART. 141	23
ART. 33	34	ART. 87	29	ART. 142	19
ART. 34	40	ART. 88	26	ART. 143	12
ART. 35	33	ART. 89	30	ART. 145	13
ART. 36	25	ART. 90	35	ART. 150	14
ART. 37	22	ART. 92	21	ART. 160	15
ART. 38	34	ART. 93	23	ART. 170	33
ART. 40	28	ART. 94	46	ASP. 01 - HP2	54
ART. 41	28	ART. 95	47	ASP. 01 - HP4	54
ART. 42	28	ART. 97	10	ASP. 02	54
ART. 43	26	ART. 98	38	ASP. 03	54
ART. 45	30	ART. 99	38	ASP. 04	54
ART. 46	45	ART. 100	52	ASP. 06	55
ART. 52	37	ART. 101	52	ASP. 07	55
ART. 53	22	ART. 102	52	BAS. 01	55
ART. 56	18	ART. 103	52	BAS. 02	55
ART. 57	43	ART. 104	53		
ART. 58	43	ART. 105	50		

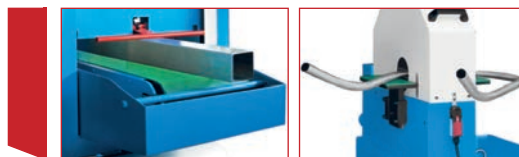

Satinatrici **6-17**

Belt grinding machines
for satin finishing

Machines à satiner

Satiniermaschinen

- | | |
|------------------|-------------------|
| ■ ART. 65.....16 | ■ ART. 143.....12 |
| ■ ART. 76.....6 | ■ ART. 145.....13 |
| ■ ART. 78.....16 | ■ ART. 150.....14 |
| ■ ART. 97.....10 | ■ ART. 160.....15 |



Levigatrici per incavi **18-20**

Pipe notching machines

Grugeuses de tubes

Rohrausschleifmaschinen

- | | |
|------------------|-------------------|
| ■ ART. 56.....18 | ■ ART. 130.....20 |
| ■ ART. 60.....18 | ■ ART. 142.....19 |

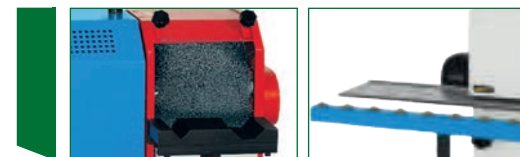

Sbavalamiere **21-22**

Sbavatubi

Sheet metal deburring machines

Tube deburring machines

Ebavureuses de tôles

Ebavureuses de tubes

Blechentgratmaschinen

Rohrentgratmaschinen

- | | |
|------------------|------------------|
| ■ ART. 37.....22 | ■ ART. 81.....21 |
| ■ ART. 53.....22 | ■ ART. 92.....21 |



Smussatrici **23-28**

Bevelling machines

Chanfreineuses

Kantenfräsmaschinen

- | | |
|------------------|-------------------|
| ■ ART. 01.....24 | ■ ART. 42.....28 |
| ■ ART. 02.....25 | ■ ART. 43.....26 |
| ■ ART. 03.....25 | ■ ART. 61.....26 |
| ■ ART. 04.....25 | ■ ART. 83.....26 |
| ■ ART. 15.....27 | ■ ART. 84.....28 |
| ■ ART. 19.....27 | ■ ART. 85.....27 |
| ■ ART. 36.....25 | ■ ART. 88.....26 |
| ■ ART. 40.....28 | ■ ART. 93.....23 |
| ■ ART. 41.....28 | ■ ART. 141.....23 |

AVVISI

- Le misure lineari del catalogo si intendono in mm.
- I pesi delle macchine si intendono al netto dell'imballaggio.
- In ogni richiesta, vogliate sempre indicare il Vostro voltaggio!
- Per i vari accessori consultate il relativo listino e/o interpellateci.
- La Ditta Aceti Macchine s.n.c. si riserva di modificare e migliorare le proprie macchine, senza obbligo di preavviso.

WARNINGS

- Linear sizes in the catalogue are meant in mm.
- Weights of the machines are meant nett, without packing.
- State your voltage in your enquiries!
- For various accessories, kindly check the pricelist too, or ask us for details.
- Aceti Macchine s.n.c. reserves the right to modify or improve its machinery without previous notice.

AVIS

- Toute mesures données s'entendent en mm.
- Les poids des machines s'entendent net d'emballage.
- Dans vos négociations, veuillez toujours mentionner votre voltage!
- Pour les accessoires, référez-vous à la liste des prix, ou consultez nous.
- Aceti Macchine s.n.c. se réserve le droit de modifier ou améliorer ses machines sans obligation de préavis.

ACHTUNG

- Die Masse des Kataloges verstehen sich in mm.
- Die im Katalog angegebene Gewichte, verstehen sich ohne Verpackung.
- Wir bitten Sie, bei den Motoren, immer ihre Spannung anzugeben!
- Was das Zubehör betrifft, bitten wir Sie die Preisliste zu ratezuziehen.
- Die Firma Aceti Macchine s.n.c., behält sich das Recht vor, eventuelle Änderungen ohne vorherige Bekanntmachung vorzunehmen.

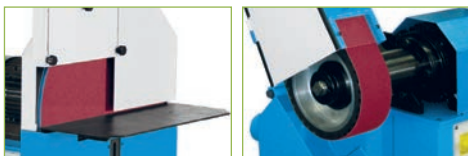

Levigatrici a nastro **29-44**
Levigatrici a disco

Belt grinding machines
Disc grinding machines

Ponceuses à bande
Ponceuses à disque

Bandschleifmaschinen
Tellerschleifmaschinen

■ ART. 05.....32	■ ART. 59.....36
■ ART. 06.....32	■ ART. 62.....37
■ ART. 07.....31	■ ART. 63.....31
■ ART. 08.....32	■ ART. 64.....36
■ ART. 16.....31	■ ART. 67.....34
■ ART. 17.....31	■ ART. 68.....41
■ ART. 21.....38	■ ART. 70.....44
■ ART. 22.....30	■ ART. 72.....44
■ ART. 23.....40	■ ART. 73 N.....35
■ ART. 24.....37	■ ART. 82.....29
■ ART. 26.....39	■ ART. 86.....29
■ ART. 28.....41	■ ART. 87.....29
■ ART. 29.....41	■ ART. 89.....30
■ ART. 30.....39	■ ART. 90.....35
■ ART. 31.....39	■ ART. 98.....38
■ ART. 32.....40	■ ART. 99.....38
■ ART. 33.....34	■ ART. 127.....32
■ ART. 34.....40	■ ART. 128.....42
■ ART. 35.....33	■ ART. 129.....42
■ ART. 38.....34	■ ART. 131.....33
■ ART. 45.....30	■ ART. 135.....30
■ ART. 52.....37	■ ART. 136.....29
■ ART. 57.....43	■ ART. 170.....33
■ ART. 58.....43	

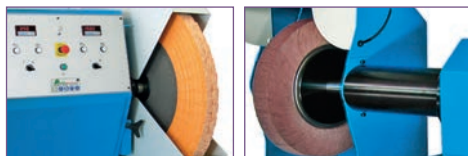

Pulitrici **45-48**
Polishing machines

Polisseuses

Poliermaschinen

■ ART. 27.....45	■ ART. 94.....46
■ ART. 46.....45	■ ART. 95.....47
■ ART. 66.....45	■ ART. 132.....49
■ ART. 71.....46	■ ART. 139.....48
■ ART. 74.....45	■ ART. 140.....48

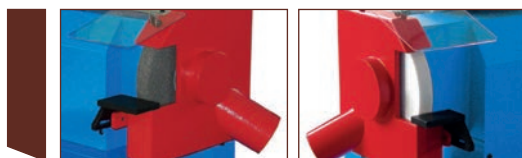

Smerigliatrici a mola **49-50**
Grinding machines

Tourets à meuler

Scheibenschleifmaschinen

■ ART. 105.....50	■ ART. 109.....50
■ ART. 106.....50	■ ART. 110.....50
■ ART. 107.....50	■ ART. 133.....49
■ ART. 108.....50	■ ART. 134.....49

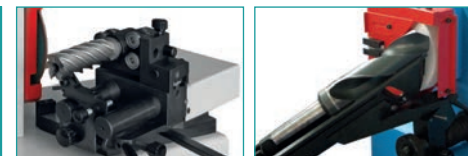

Affilapunte - Affilafrese **51-53**
Affilautensili

Drill sharpening - End mill sharpening
Tool sharpening machines

Affûteuses de forets - Affûteuses
de fraises - Affûteuses d'outils

Spiralbohrerschleifmaschinen

Fräuserschleifmaschinen

Stähleschleifmaschinen

■ ART. 100.....52	■ ART. 112.....53
■ ART. 101.....52	■ ART. 113.....51
■ ART. 102.....52	■ ART. 114.....53
■ ART. 103.....52	■ ART. 115.....53
■ ART. 104.....53	■ ART. 119.....51



Aspiratori per polveri **54-55**
Dust Extractors

Aspirateurs





Staub-Absauganlagen

■ ASP. 01 - HP254	■ ASP. 06.....55
■ ASP. 01 - HP454	■ ASP. 07.....55
■ ASP. 02.....54	■ BAS. 01.....55
■ ASP. 03.....54	■ BAS. 02.....55
■ ASP. 04.....54	

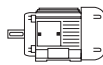
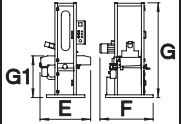

ART.
76

SATINATRICE - LEVIGATRICE AD UMIDO E A SECCO
 SATINING - BELT GRINDING MACHINE WITH WET SYSTEM AND DRY SYSTEM
 MACHINE A SATINER - PONCEUSE AVEC ARROSAGE ET A SEC
 SATINIERMACHINE - BANDSCHLEIFMASCHINE MIT NASS SYSTEM UND TROCKEN SYSTEM

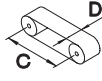
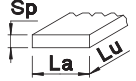
																
Volt 400 kW 4,6																
hp	Rpm	m/s	E	F	G	G1	dB	kg	A	B	C	D	m/min	Sp	La max	Lu min
6	1500	8	1250	1200	2100	900	85	625	1900	300	830	300	1+10	0+205	300	140

- Tensionamento pneumatico del nastro abrasivo
- Pneumatic tensioning of the abrasive belt
- Tension pneumatique de la bande abrasive
- Schleifband mit pneumatischem Spannzyliner



- Pannello elettrico a bassa tensione posizionato su fronte macchina
- Low tension electrical panel placed in front of the machine
- Coffret électrique basse tension positionné à l'avant de la machine
- Niederspannung Schalttafel platziert vor der Maschine



- Motore elettrico con frenatura meccanica per arresto rapido della macchina
- Electric motor with mechanical brake for rapid stop of the machine
- Moteur électrique avec frein mécanique pour arrêt rapide de la machine
- Elektromotor mit mechanischer Bremse für schnellen Maschinenstop



- Unità di trattamento aria compressa composta da: elettrovalvola di comando - regolatore - filtro
- Compressed air treatment unit composed of: driving valve - regulator - filter
- Unite de traitement d'air comprimé composée de: électrovalve de commande - régulateur - filter
- Druckluftwartungseinheit bestehend aus: Druckminderer - Regler - Filter



- Pistola per pulizia della macchina e particolari
- Gun for cleaning the machine and the pieces
- Pistolet de nettoyage de la machine et des pièces
- Pistole zur Reinigung der Maschine und der mechanischen Teile



- Impianto refrigerante completo di: vasca di raccolta e ricircolo 70 litri - triplo sistema di filtraggio (A-B-C)
- Coolant device equipped: tank capacity 70 liters - Three filter system (A-B-C)
- Dispositif d'arrosage fourni avec: réservoir capacité 70 litres - système avec triple filters (A-B-C)
- Wasserkühlung mit: Tankinhalt 70 Liter - Bandfilterrolle (A), Bandfilter (B) und Filterpatrone (C)

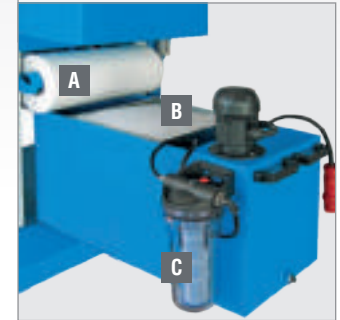

- Lettore micrometrico per lo spessore del particolare in lavorazione
- Micrometric meter thickness of the workpiece
- Lecteur micrométrique de l'épaisseur de la pièce à travailler
- Handrad mit Scala zur Einstellung der Materialstärke



- Dispositivo salvamani in ingresso con arresto di emergenza
- Hand protecting device at the entrance with emergency stop
- Dispositif de protection pour les mains à l'entrée avec arrêt d'urgence
- Berührungsschutz am Einlauf der Maschine mit Not-Aus Funktion



- Dispositivo di soffiatura per pulizia nastro trasportatore
- Blowing device for cleaning the conveyor belt
- Dispositif de soufflage pour nettoyage du tapis transporteur
- Druckluftblasvorrichtung zur Reinigung des Transportbandes



- Cappa d'aspirazione per lavorazione a "secco"
- Hotte d'aspiration pour travail "à sec"
- Absaugstutzen für den Einsatz bei trockenem Schliff



- Velocità di avanzamento variabile da 1 a 10 m/min
- Variable feed speed from 1 to 10 m/min
- Vitesse d'avance variable de 1 à 10 m/min
- Stufenlose Vorschubeinstellung von 1÷10 m/min

RUL.76

- Rulliera: moduli da 1,5 m
- Roller table: module of 1,5 m
- Servante à rouleaux: modules de 1,5 m
- Zufuhrrollenbahn: Länge 1,5 m



M2V.76

- Doppia velocità del nastro abrasivo
- Double speeds of the abrasive belt
- Double vitesses de la bande abrasive
- Zwei Geschwindigkeiten für das Schleifband



INV.76

- Inverter per la regolazione elettronica della velocità del nastro abrasivo da 0 a 3000 giri/min
- Inverter for the electronic adjustment of the speed of the abrasive belt from 0 to 3000 Rpm
- Variateur pour le réglage électronique de la vitesse de la bande abrasive de 0 à 3000 T/min
- Inverter für stufenlose elektronische Regulierung der Schleifbandgeschwindigkeit von 0 bis 3000 UpM



SPU.76

- Dispositivo di soffiatura dei particolari in uscita
- Blowing device of the parts in exit
- Dispositif de soufflage des pièces en sortie
- Druckluft-Trocknungseinheit für Material



VRA

- Vasca di raccolta e ricircolo liquido refrigerante con filtraggio automatico, capacità 170 litri
- Tank of collection the coolant liquid with automatic filtering, capacity 170 litres
- Réservoir pour recueillir le liquide de refroidissement avec filtrage automatique, capacité 170 litres
- Automatische Filtereinrichtung, Kapazität 170 Liter





ART. 76

Unità di levigatura
Belt grinding unit
Unité de ponçage
Schleifaggregat

A	B
1900	300



ART. 76 2N

2 Unità di levigatura
2 Belt grinding units
2 Unité de ponçage
2 Schleifaggregate

A	B	A	B
1900	300	1900	300

ART. 76 1N+1S

Unità di levigatura + Unità di spazzolatura
Belt grinding unit + Brushing unit
Unité de ponçage + Unité de brosse
Schleifaggregat + Bürstaggreat

A	B	Ø mm
1900	300	Ø200 x 300



ART. 76 2N+1S

2 Unità di levigatura + Unità di spazzolatura
2 Belt grinding units + Brushing unit
2 Unité de ponçage + Unité de brosse
2 Schleifaggregate + Bürstaggreat

A	B	A	B	Ø mm
1900	300	1900	300	Ø200 x 300





- Tensionamento del nastro abrasivo
- Tensioning of the abrasive belt
- Tension de la bande abrasive
- Schleifband Spannzylinder

- Doppia velocità del nastro abrasivo
- Double speeds of the abrasive belt
- Double vitesses de la bande abrasive
- Zwei Geschwindigkeiten für das Schleifband



Pannello elettrico a bassa tensione posizionato su fronte macchina con: ■
ammeter, selettore a due velocità nastro abrasivo, selettore nastro trasportatore, pulsante stop emergenza per arresto rapido della macchina

Low tension electrical panel placed in front of the machine with: ■
ammeter, two speed switch of abrasive belt, conveyor belt switch, emergency stop button for rapid stop of the machine

Coffret électrique basse tension positionné à l'avant de la machine avec: ■
ampèremètre, sélecteur à deux vitesses de la bande abrasive, sélecteur du tapis transporteur, bouton d'arrêt d'urgence avec arrêt rapide de la machine

Niederspannung Schalttafel platziert vor der Maschine mit: ■
Amperemeter, zwei Geschwindigkeiten Schleifband-Schalt, Förderband-Schalt, Not-Aus-Taster für schnellen Maschinenstop

ART. 97		SATINATRICE - LEVIGATRICE A SECCO SATINING - BELT GRINDING MACHINE WITH DRY SYSTEM MACHINE À SATINER - PONCEUSE A SEC SATINIERMASCHINE - BANDSCHLEIFMASCHINE MIT TROCKEN SYSTEM												
Volt 400 kW 5	E F G G1	dB	kg	A B	C D	m/min	Sp	La max	Lu min					
6,5 1400 2800	1250 870 1850 850	80	570	1750 220	1000 220	1+10	0+125	220	120					



EQUIPEMENTS STANDARD
STANDARD ZUBEHÖR

- Cappa d'aspirazione
- Dust hood
- Hotte d'aspiration
- Absaugstutzen

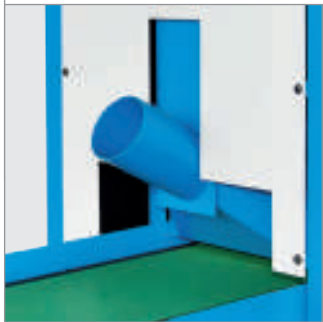

- Motore elettrico con scheda frenatura elettronica
- Electric motor with electronic braking card
- Moteur électrique avec carte électronique de freinage
- Elektromotor mit Elektronischer Bremsung karte



- Lettore micrometrico per lo spessore del particolare in lavorazione
- Micrometric meter thickness of the workpiece
- Lecteur micrométrique de l'épaisseur de la pièce à travailler
- Handrad mit Scala zur Einstellung der Materialstärke



- Velocità di avanzamento variabile da 1 a 10 m/min
- Variable feed speed from 1 to 10 m/min
- Vitesse d'avance variable de 1 à 10 m/min
- Stufenlose Vorschubeinstellung von 1-10 m/min

ART. 97 ACCESSORI OPTIONAL | OPTIONAL EQUIPMENT
EQUIPEMENTS OPTIONAL | OPTIONAL ZUBEHÖR

ART. 97 2N

- 2 Unità di levigatura
- 2 Belt grinding units
- 2 Unité de ponçage
- 2 Schleifaggregate

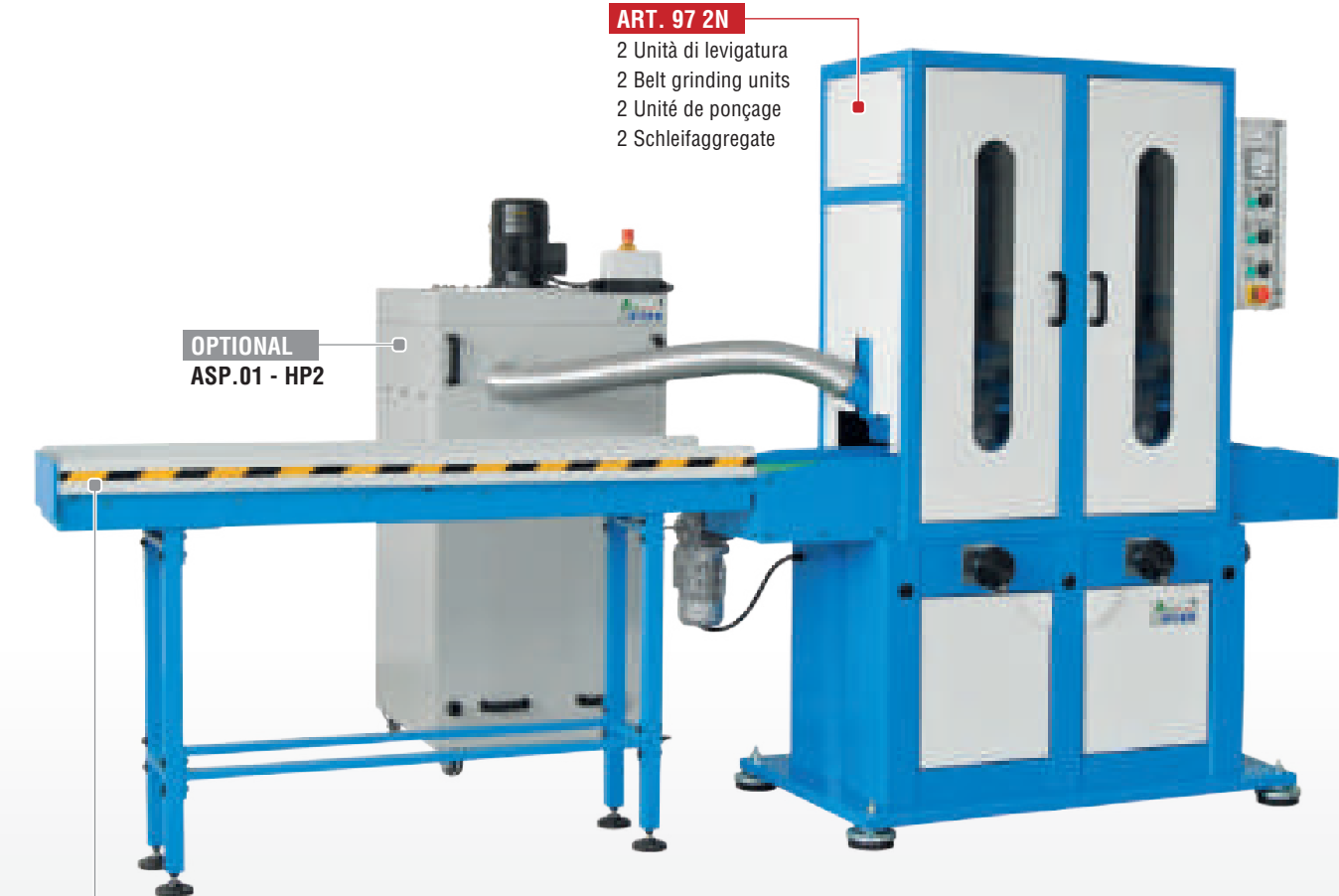

OPTIONAL
ASP.01 - HP2



RUL.97

- Rulliera: moduli da 1,5 m
- Roller table: module of 1,5 m
- Servante à rouleaux: modules de 1,5 m
- Zufuhrrollenbahn: Länge 1,5 m



INV.97

- Inverter per la regolazione elettronica della velocità del nastro abrasivo da 0 a 3000 giri/min
- Inverter for the electronic adjustment of the speed of the abrasive belt from 0 to 3000 Rpm
- Variateur pour le réglage électronique de la vitesse de la bande abrasive de 0 à 3000 T/min
- Inverter für stufenlose elektronische Regulierung der Schleifbandgeschwindigkeit von 0 bis 3000 UpM



OPTIONAL

INV.143

- Inverter per la regolazione elettronica della velocità del nastro abrasivo da 0 a 3000 giri/min
- Inverter for the electronic adjustment of the speed of the abrasive belt from 0 to 3000 Rpm
- Variateur pour le réglage électronique de la vitesse de la bande abrasive de 0 à 3000 T/min
- Inverter für stufenlose elektronische Regulierung der Schleifbandgeschwindigkeit von 0 bis 3000 UpM



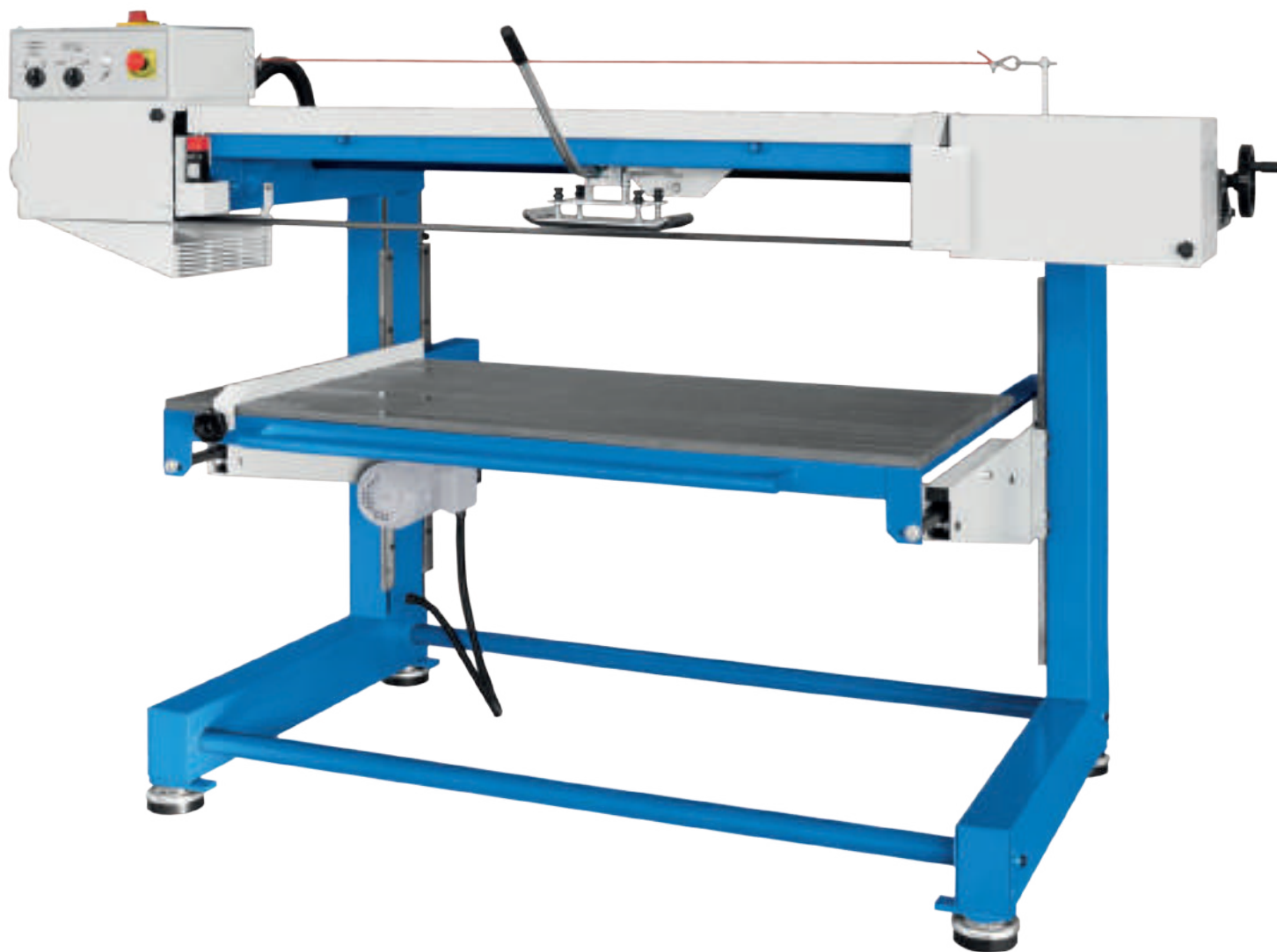





ART. 143		SATINATRICE - LEVIGATRICE A TAMPONE SATINING - BELT GRINDING MACHINE WITH PAD MACHINE À SATINER - PONCEUSE AVEC TAMPON SATINIERMASCHINE - BANDSCHLEIFMASCHINE MIT DRUCKSTÜK																
Volt 400 kW 1,5																		
hp	Rpm	m/s	E	F	G	G1	dB	kg	A	B	Sp	La	Lu	kg max	INCLUDED	TAR.143	OPTIONAL INVERTER	OPTIONAL ASP.01
2	1400 2800	11 22	2000	1200	1700	490÷1050	70	230	4000	120	1÷560	550	1500	50	Nr.1	Nr.1	Rpm 0÷3000	kW 1,5

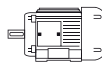

OPTIONAL

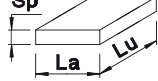
INV.145

- Inverter per la regolazione elettronica della velocità del nastro abrasivo da 0 a 3000 giri/min
- Inverter for the electronic adjustment of the speed of the abrasive belt from 0 to 3000 Rpm
- Variateur pour le réglage électronique de la vitesse de la bande abrasive de 0 à 3000 T/min
- Inverter für stufenlose elektronische Regulierung der Schleifbandgeschwindigkeit von 0 bis 3000 UpM

 ART. 145		SATINATRICE - LEVIGATRICE A TAMPONE PROFESSIONAL PROFESSIONAL SATINING - BELT GRINDING MACHINE WITH PAD MACHINE À SATINER - PONCEUSE PROFESSIONNEL AVEC TAMPON SATINIERMASCHINE - BANDSCHLEIFMASCHINE MIT DRUCKSTÜK																		
																				
Volt 400 kW 2,2		hp	Rpm	m/s	E	F	G	G1	dB	kg	A	B	Sp	La	Lu	kg max	INCLUDED	TAR.145	INVERTER	ASP.01
		3	1400 2800	11 22	2700	1750	1700	600+1150	85	350	4700	120	1+540	700	1500	100	Nr.1	Nr.1	Rpm 0+3000	kW 3



ART. 150 2N

- 2 Unità di levigatura
- 2 Belt grinding units
- 2 Unité de ponçage
- 2 Schleifaggregate

ART. 150 3N

- 3 Unità di levigatura
- 3 Belt grinding units
- 3 Unité de ponçage
- 3 Schleifaggregate

ART. 150 4N

- 4 Unità di levigatura
- 4 Belt grinding units
- 4 Unité de ponçage
- 4 Schleifaggregate



OPTIONAL

AV.2R

- Velocità di avanzamento variabile da 1 a 5 m/min
- Variable feed speed from 1 to 5 m/min
- Vitesse d'avance variable de 1 à 5 m/min
- Stufenlose Vorschubeinstellung von 1÷5 m/min



OPTIONAL

INV.150

- Inverter per la regolazione elettronica della velocità del nastro abrasivo da 0 a 3000 giri/min
- Inverter for the electronic adjustment of the speed of the abrasive belt from 0 to 3000 Rpm
- Variateur pour le réglage électronique de la vitesse de la bande abrasive de 0 à 3000 T/min
- Inverter für stufenlose elektronische Regulierung der Schleifbandgeschwindigkeit von 0 bis 3000 UpM



ART. 150

SATINATRICE - LEVIGATRICE "PLANETARIA" A SECCO
 "PLANETARY" SATINING - BELT GRINDING MACHINE WITH DRY SYSTEM
 MACHINE À SATINER - PONCEUSE À BANDES "PLANÉTAIRES" A SEC
 "PLANETARISCHE" SATINIERMASCHINE - BANDSCHLEIFMASCHINE MIT TROCKEN SYSTEM

Volt 400 kW 1,85		Volt 400 kW 3,0		E F G G1		dB kg		kg A B		Ø mm R min		OPTIONAL ASP.01		OPTIONAL		OPTIONAL: AUTOMATIC ADVANCING -AV.2R-		kW Rpm m/min		Ø mm			
2,5	1400	4	1400	10	20	910	750	1550	1000	80	360	900	60	Min 5 + 120	Max	150	ASP.01	INVERTER	0,25	1400	1+5	Min 5 + 120	Max



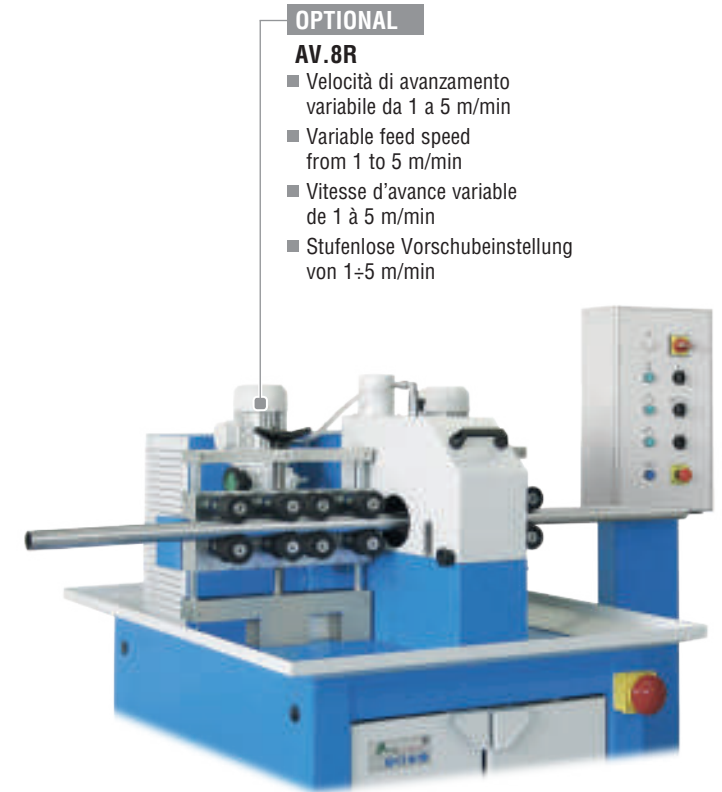







OPTIONAL

AV.8R

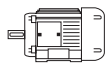
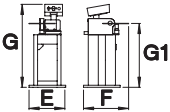

- Velocità di avanzamento variabile da 1 a 5 m/min
- Variable feed speed from 1 to 5 m/min
- Vitesse d'avance variable de 1 à 5 m/min
- Stufenlose Vorschubeinstellung von 1÷5 m/min

ART. 160															SATINATRICE - LEVIGATRICE "PLANETARIA" AD UMIDO E A SECCO "PLANETARY" SATINING - BELT GRINDING MACHINE WITH WET SYSTEM AND DRY SYSTEM MACHINE À SATINER - PONCEUSE À BANDES "PLANÉTAIRES" AVEC ARROSAGE ET A SEC "PLANETARISCHE" SATINIERMASCHINE - BANDSCHLEIFMASCHINE MIT NASS SYSTEM UND TROCKEN SYSTEM																				
Volt 400 kW 1,85			Volt 400 kW 3,0			G			G1			dB			kg			Nr. 2			Ø mm			R min			OPTIONAL ASP.01			OPTIONAL INVERTER Rpm 0÷3000			OPTIONAL: AUTOMATIC ADVANCING -AV.8R-		
hp	Rpm		hp	Rpm	m/s	E	F	G	G1				A	B												kW	Rpm	m/min	Ø mm						
2,5	1400		4	1400 2800	10 20	1300	1000	1400	1045	80	550	900	60	Min 5 ÷ 120	Max	150	kW 1,5									0,25	1400	1÷5	Min 5 ÷ 120	Max					



ART. 78		SATINATRICE - LEVIGATRICE "PLANETARIA" "PLANETARY" SATINING - BELT GRINDING MACHINE MACHINE À SATINER - PONCEUSE À BANDES "PLANETAIRES" "PLANETARISCHE" SATINIERMASCHINE - BANDSCHLEIFMASCHINE							
									
Volt 400 kW 0,75									
hp	Rpm	m/s	E	F	G	G1	dB	kg	
1	1500	7	540	665	1223	940	85	90	
									
Nr. 2								OPTIONAL	
A	B	Ø mm		R min		IA-1			
280	11	Min 4 ÷ 20 Max		40		kW 0,55			

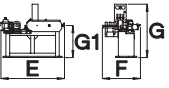

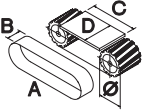
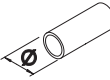
ART. 65		SATINATRICE - LEVIGATRICE "CENTERLESS" AD UMIDO "CENTERLESS" SATINING - BELT GRINDING MACHINE WITH WET SYSTEM MACHINE À SATINER - PONCEUSE "CENTERLESS" AVEC ARROSAGE "CENTERLESS" SATINIERMASCHINE - BANDSCHLEIFMASCHINE MIT NASS SYSTEM												
														
Volt 400 kW 5,2														
hp	Rpm	m/s	E	F	G	G1	dB	kg	A	B	C	D	Ø mm	Ø mm
7	1400 2800	18 36	1650	1000	1650	1010	75	385	2000	75	470	100	Ø250x75	Min 10 ÷ 115 Max

ART. 65 ACCESSORI STANDARD | STANDARD EQUIPMENT
EQUIPEMENTS STANDARD | STANDARD ZUBEHÖR

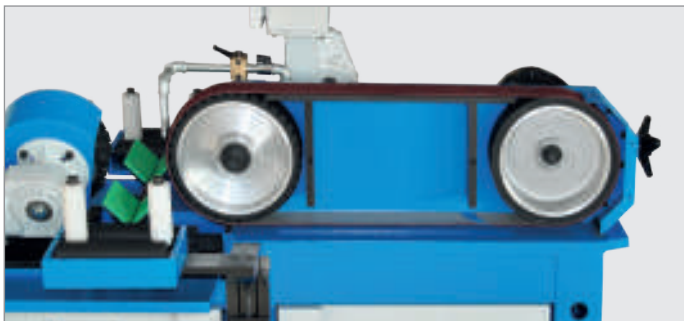

- Supporto dei particolari in lavorazione con tavole a rulli gommati regolabili
- Support of the workpieces with adjustable rubber roller tables
- Support des pièces à travailler avec réglable tables à rouleaux en caoutchouc
- Unterstützung der Werkstücke mit verstellbaren Gummiwalze Tabellen



- Pannello elettrico a bassa tensione posizionato su fronte macchina
- Low tension electrical panel placed on the front of the machine
- Coffret électrique basse tension positionné à l'avant de la machine
- Niederspannung Schalttafel platziert vor der Maschine



- Motore elettrico a due velocità con scheda frenatura elettronica
- Double speeds electric motor with electronic braking card
- Moteur électrique à deux vitesses avec carte électronique de freinage
- Zwei Geschwindigkeiten Elektromotor mit Elektronischer Bremsung karte



- Velocità di avanzamento variabile da 1 a 5 m/min
- Variable feed speed from 1 to 5 m/min
- Vitesse d'avance variable de 1 à 5 m/min
- Stufenlose Vorschubeinstellung von 1÷5 m/min



- Impianto refrigerante completo di: vasca di raccolta e ricircolo 50 litri - sistema di filtraggio
- Coolant device equipped: tank capacity 50 liters - filtering system
- Dispositif d'arrosage fourni avec: réservoir capacité 50 litres - système de filtrage
- Wasserkühlung mit: Tankinhalt 50 Liter - Filtersystem





ART. 65 ACCESSORI OPTIONAL
OPTIONAL EQUIPMENT
EQUIPEMENTS OPTIONAL
OPTIONAL ZUBEHÖR



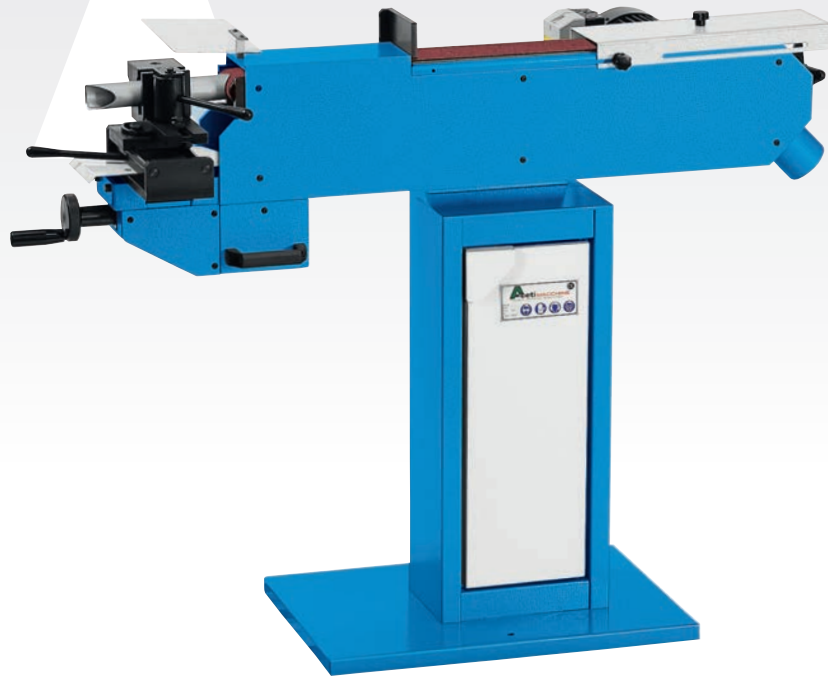

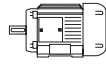
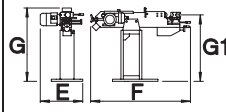

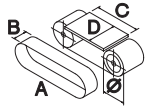
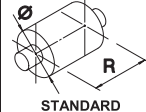
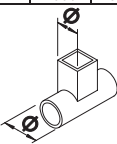
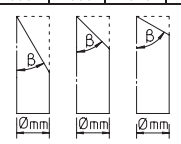
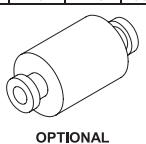
VRA

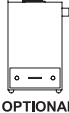
- Vasca di raccolta e ricircolo liquido refrigerante con filtraggio automatico, capacità 170 litri
- Tank of collection the coolant liquid with automatic filtering, capacity 170 litres
- Réservoir pour recueillir le liquide de refroidissement avec filtrage automatique, capacité 170 litres
- Automatische Filtereinrichtung, Kapazität 170 Liter

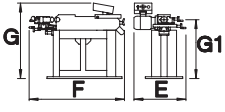

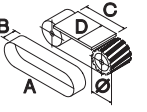
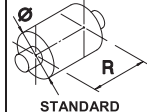
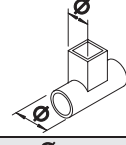
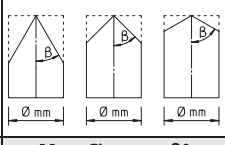
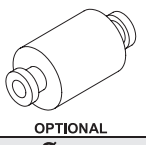



ART. 60		LEVIGATRICE PER INCAVI PIPE NOTCHER MACHINE GRUGEUSE DE TUBES ROHRAUSSCHLEIFER													
															
Volt 400 kW 3							kg					STANDARD			
hp	Rpm	m/s	E	F	G	G1	dB	kg	A	B	C	D	Ø	Ø"	R
4	2800	30	650	1500	1040	960	70	125	2000	75	400	75	200	Ø1" ¼	75
															
Ø mm		Max Ø mm x β°			Ø		kW		Rpm	m/s	ASP.01				
Min 20 ÷ 70 Max		37x30° 52x45° 64x60°			20 -½"-¾"-1"-1"½"-2"-70		3		1400 2800	15 30	kW 1,5				

ART. 56		LEVIGATRICE PER INCAVI PROFESSIONAL PROFESSIONAL PIPE NOTCHER MACHINE GRUGEUSE DE TUBES PROFESSIONNELLE BERUFLICHE ROHRAUSSCHLEIFER													
															
Volt 400 kW 5,2							kg					STANDARD			
hp	Rpm	m/s	E	F	G	G1	dB	kg	A	B	C	D	Ø	Ø"	R
7	1400 2800	15 30	800	1600	1250	1000	75	280	2000	150	400	160	200	Ø¾" - Ø1" ¼ - 3"	160
															
Ø mm		Max Ø mm x β°			Ø mm		kW		Rpm	m/s	ASP.01				
Min 20 ÷ 145 Max		70x30° 102x45° 125x60°			20 ÷ 145		kW 1,5		1400 2800	15 30					

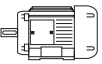
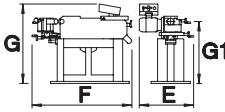

ART.
142

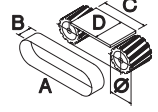
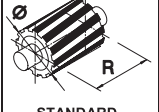
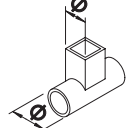
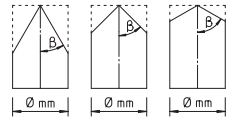
LEVIGATRICE PER INCAVI PROFESSIONAL
PROFESSIONAL PIPE NOTCHER MACHINE
GRUGEUSE DE TUBES PROFESSIONNELLE
BERUFLICHE ROHRAUSSCHLEIFER

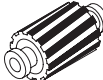
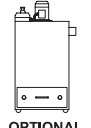
 Volt 400 kW 6,5											 STANDARD					OPTIONALS  		 OPTIONAL		
hp	Rpm	m/s	E	F	G	G1	dB	kg	A	B	C	D	Ø	Ø"	R	Ø mm	Max Ø mm x β°	Ø mm	Ø mm	ASP.01
9	1400	18	930	1900	1360	1010	75	430	2500	250	460	300	250	Ø 5"	250	Min 30 ÷ 245 Max	121x30° 170x45° 210x60°	30 ÷ 100	101 ÷ 245	kW 1,5

ART. 130



Posizione orizzontale
Horizontal position
Position horizontal
Horizontaler stellung



ART. 130











Posizione verticale
Vertical position
Position vertical
Vertikaler stellung





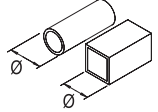





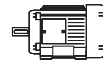

ART. 130		LEVIGATRICE PER INCAVI UNIVERSALE CON NASTRO ABRASIVO ORIENTABILE IN POSIZIONE ORIZZONTALE E VERTICALE UNIVERSAL PIPE NOTCHER MACHINE WITH ABRASIVE BELT ADJUSTABLE IN HORIZONTAL AND VERTICAL POSITIONS GRUGEUSE DE TUBES UNIVERSELLE A BANDE ABRASIVE REGLABLE EN POSITION HORIZONTAL ET VERTICAL UNIVERSELLE ROHRAUSSCHLEIFER MIT SCHLEIFBAND EINSTELLBAR IN HORIZONTALER - VERTIKALER STELLUNG													
Volts 400 kW 5.2					STANDARD			OPTIONAL	OPTIONAL						
hp Rpm m/s	E F G G1	dB	kg	A B C D Ø	Ø " R	Ø mm	Max Ø mm x β°	Ø mm	ASP.01						
7 1400 15 2800 30	950 1650 1250 1000	75	310	2000 150 400 160 200	Ø¼" - Ø1" ¼ - Ø3" 160	Min 20 ÷ 145 Max	70x30° 102x45° 125x60°	20 ÷ 145	kW 1.5						

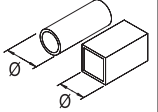

ART. 92		SBAVATRICE PER TUBI SINGOLA SINGLE DEBURRING MACHINE FOR PIPES EBARBEUSE POUR TUBES ENTGRATMASCHINE FÜR ROHRE								
										
Volt 400 kW 4,4										
hp	Rpm	m/s	dB	E	F	G	G1	kg		
6	1400 2800	18 36	75	670	540	1150	960	155		
						OPTIONAL				
Arm A		Arm A		Arm A		IA-1				
Max Ø60		Ø250x60xØ100		kW 0,55						











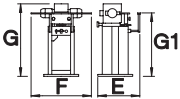



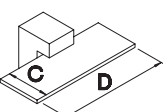
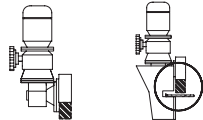
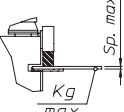

ART. 81		SBAVATRICE PER TUBI DOPPIA DOUBLE DEBURRING MACHINE FOR PIPES EBARBEUSE POUR TUBES (2 POSTES) ENTGRATMASCHINE FÜR ROHRE								
										
Volt 400 kW 4,4										
hp	Rpm	m/s	dB	E	F	G	G1	kg		
6	1400 2800	18 36	75	850	540	1150	960	180		
								OPTIONAL		
Arm A		Arm B		Arm A		Arm B		IA-2		
Max Ø60		Max Ø120		Ø250x60xØ100		Ø250x120xØ100		kW 0,55		

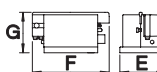

OPTIONAL
AV.37
Automatic
Advancing

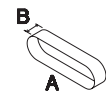

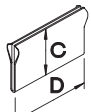
ART. 37		SBAVALAMIERA DEBURRING MACHINE EBARBEUSE RECTO/VERSO A ROUES LAMELLÉES BLECHENTGRATMASCHINE									
 Nr.2 Volt 400 kW 0,75						 Nr. 2					
hp	Rpm	m/s	E	F	G	G1	dB	kg	Ø mm	Sp	
1	1400	18	700	1000	1200	990	72	140	Ø250x50xØ100	0÷4	
											
		OPTIONAL: AUTOMATIC ADVANCING -AV.37-				OPTIONAL					
C	D		kW	Rpm	m/min	Sp. max	kg max	IA-1			
120	1000		0,20	1400	1÷5	4	35	kW 0,55			

ART. 53		SBAVALAMIERA DA BANCO DEBURRING MACHINE FOR DESK EBARBEUSE RECTO/VERSO DE BANC BLECHENTGRATMASCHINE FÜR WERKBANK									
 Volt 400 kW 1,1											
hp	Rpm	m/s	dB	E	F	G	kg				
1,5	2800	16	70	320	540	300	21				
 Nr. 2											
						OPTIONAL					
A	B	Sp		C	D	ASP.04					
500	20	0÷2		75	540	kW 0,55					

ART.
93

SMUSSATRICE PER CARPENTERIA CON ANGOLO VARIABILE
CHAMFERING MACHINE FOR CARPENTRY WITH VARIABLE ANGLE
MACHINE A CHANFREIN DE SOUDURE AVEC ANGLE VARIABLE
KANTENFRÄSMACHINE FÜR SCHLOSSEREI MIT VARIABLER WINKEL

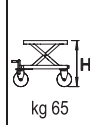
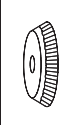
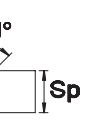
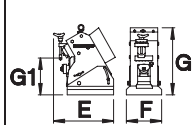
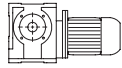

Volt 400

INCLUDED

OPTIONAL

Nm	m/min	E	F	G	G1	dB	kg	Sm	Sp	J° VARIABLE	Ømin	FR1	CAR.93
580	3	615	350	690	360	70	150	0÷18x30°	5÷60	22,5°-30°-37,5°-45°-52,5°	110	Nr.1	H=460+800



OPTIONAL
CAR.93

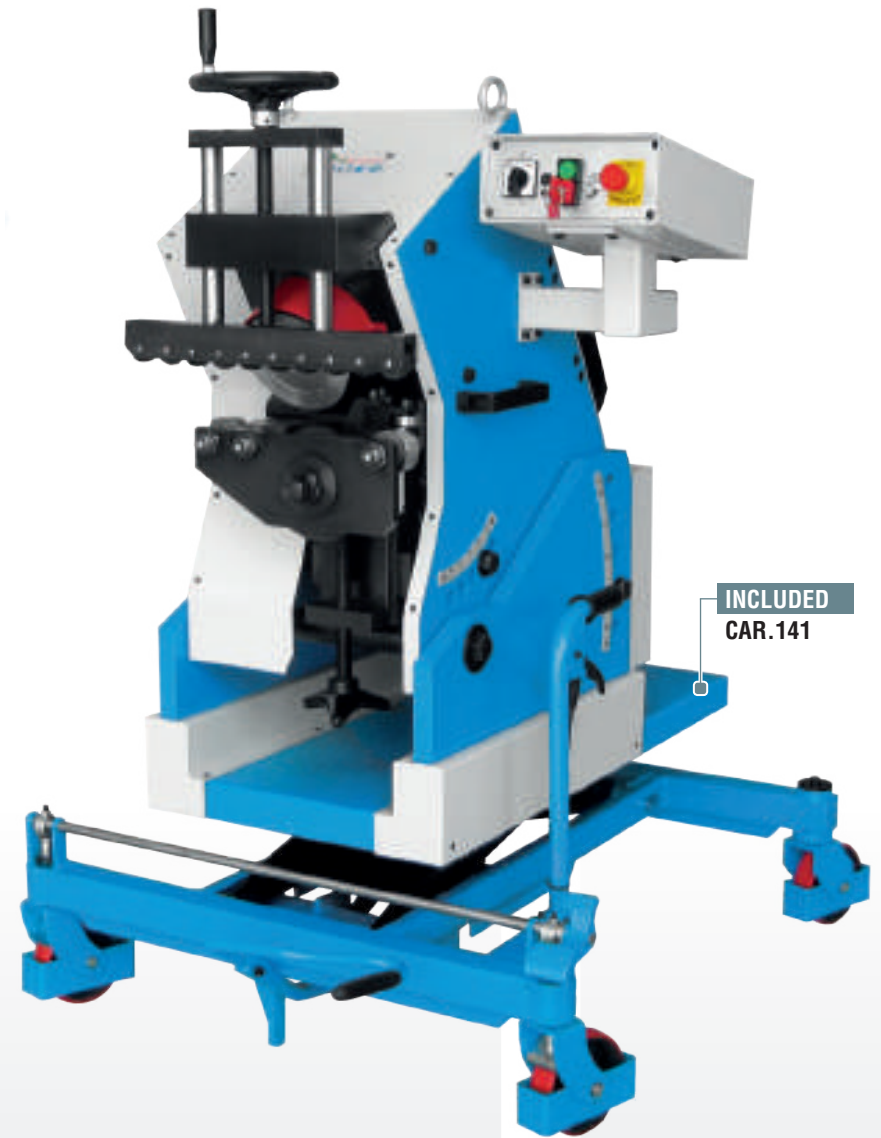

INCLUDED
CAR.141

ART.
141

SMUSSATRICE PER CARPENTERIA CON ANGOLO VARIABILE
CHAMFERING MACHINE FOR CARPENTRY WITH VARIABLE ANGLE
MACHINE A CHANFREIN DE SOUDURE AVEC ANGLE VARIABLE
KANTENFRÄSMACHINE FÜR SCHLOSSEREI MIT VARIABLER WINKEL

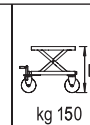
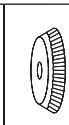
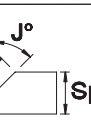
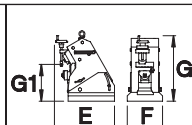
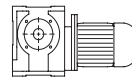

Volt 400

INCLUDED







INCLUDED

Nm	m/min	E	F	G	G1	dB	kg	Sm	Sp	J° VARIABLE	Ømin	FR3	CAR.141
2400	2,3	970	850	1000	570	70	600	0÷30x30°	8÷60	22,5°-30°-37,5°-45°-52,5°	180	Nr.1	H=420+800

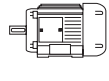
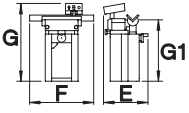

OPTIONAL

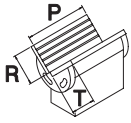
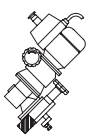
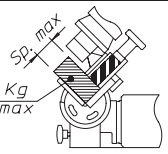
AV.01
Automatic
Advancing

ART. 01		SMUSSATRICE PROFESSIONAL PROFESSIONAL CHAMFERING MACHINE CHANFREINEUSE PROFESSIONNELLE STATIONÄRE KANTENFRÄSMASCHINE																				
																						
Volt 400 kW 2,2		E	F	G	G1	dB	kg	Ø mm	Z	Sm	J°	P	R	T	OPTIONAL: AUTOMATIC ADVANCING -AV.01-							
hp	Rpm	m/s	E	F	G	G1	dB	kg	Ø mm	Z	Sm	J°	P	R	T	kW	Rpm	m/min	Sp. max	kg max	Ø mm	Z
3	1400 2800	8 16	700	1000	1300	950	68	210	110	10	0÷8	15°÷45°	1000	120	120	0,20	1400	1÷5	50	35	110	12-24





ART. 02		SMUSSATRICE + LEVIGATRICE A NASTRO CHAMFERING + BELT GRINDING MACHINE CHANFREINEUSE + TANK KANTENFRÄS-UND BANDSCHLEIFMASCHINE							
Volt 400 kW 1,8									
hp	Rpm	m/s	dB	E	F	G	G1	kg	
2,5	1400 2800	10 20	72	600	700	1600	980	120	
A	B	C	D	Ø	P	R	T	Sm	J°
1500	120	470	120	135	500	80	100	0+6	15°+45°
ISO SPUN 12.03.08		OPTIONAL		IA-1					
Ø mm	Z								
80	10							kW 0,55	

ART. 04		SMUSSATRICE + SMERIGLIATRICE CHAMFERING + GRINDING MACHINE CHANFREINEUSE + MEULE KANTENFRÄS-UND SCHEIBENSCHLEIFM.							
Volt 400 kW 1,8									
hp	Rpm	m/s	dB	E	F	G	G1	kg	
2,5	2800	30	68	600	600	1100	950	95	
ISO SPUN 12.03.08		OPTIONAL		IA-1					
Ø mm	Z								
80	10							kW 0,55	











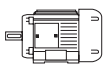

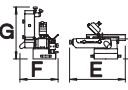

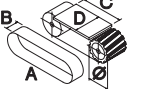

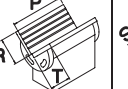

ART. 36		SMUSSATRICE + PULITRICE CHAMFERING + POLISHING MACHINE CHANFREINEUSE + POLISSOIR KANTENFRÄS-UND POLIERMASCHINE							
Volt 400 kW 1,8									
hp	Rpm	m/s	dB	E	F	G	G1	kg	
2,5	1400 2800	18 36	70	600	1000	1100	910	95	
ISO SPUN 12.03.08		OPTIONAL		IA-1					
Ø mm	Z								
80	10							kW 0,55	





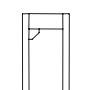





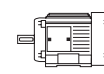

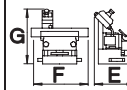
ART. 03		SMUSSATRICE CHAMFERING MACHINE CHANFREINEUSE STATIONÄRE KANTENFRÄSMASCHINE							
Volt 400 kW 1,5									
hp	Rpm	m/s	dB	E	F	G	G1	kg	
2	2800	12	68	600	600	1110	950	85	
ISO SPUN 12.03.08		OPTIONAL		IA-1					
Ø mm	Z								
80	10							kW 0,55	

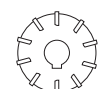

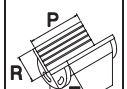







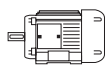

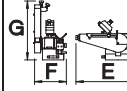

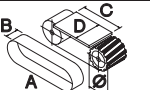

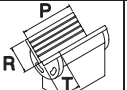

ART. 83		SMUSSATRICE + LEVIGATRICE DA BANCO CHAMFERING + GRINDING MACHINE FOR DESK CHANFREINEUSE + TANK DE BANC KANTENFRÄS-UND BANDSCHLEIFMASCHINE							
									
Volt 400 kW 1,1									
hp	Rpm	m/s	dB	E	F	G	G1	kg	
1,5	2800	15	72	730	500	680	260	47	
									
A	B	C	D	Ø mm	P	R	T	Sm	J°
1000	100	290	100	100	500	80	100	0+6	15°+45°
OPTIONALS									
									
ISO SPUN 12.03.08									
Ø mm	Z	BAS.01		ASP.04					
80	10	kg 40		kg 45					





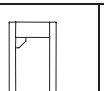



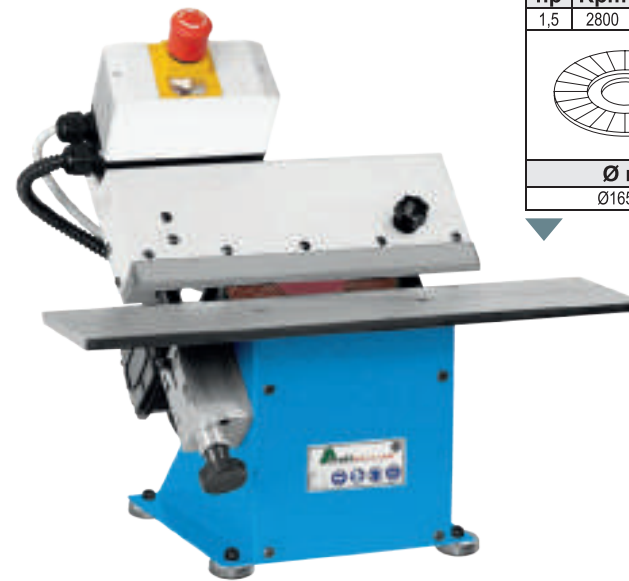

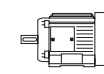

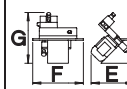
ART. 61		SMUSSATRICE DA BANCO CHAMFERING MACHINE FOR DESK CHANFREINEUSE DE BANC KANTENFRÄS-MASCHINE FÜR WERKBANK							
									
Volt 400 kW 1,1									
hp	Rpm	m/s	dB	E	F	G	G1	kg	
1,5	2800	12	68	400	500	500	245	32	
									
Ø mm	Z	P	R	T	Sm	J°			
80	10	500	80	100	0+6	15°+45°			

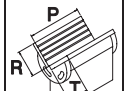

ART. 88		SMUSSATRICE + LEVIGATRICE DA BANCO CHAMFERING + GRINDING MACHINE FOR DESK CHANFREINEUSE + TANK DE BANC KANTENFRÄS-UND BANDSCHLEIFMASCHINE							
									
Volt 400 kW 1,1									
hp	Rpm	m/s	dB	E	F	G	G1	kg	
1,5	2800	30	72	760	390	710	320	42	
									
A	B	C	D	Ø mm	P	R	T	Sm	J°
1250	50	300	60	Ø200x50xØ20	500	80	100	0+6	15°+45°
OPTIONALS									
									
ISO SPUN 12.03.08									
Ø mm	Z	BAS.01		ASP.04					
80	10	kg 40		kg 45					









ART. 43		SMUSSATRICE DA BANCO A DISCO CHAMFERING MACHINE FOR DESK CHANFREINEUSE DE BANC À DISQUE VERSTELLBARE ENTGRATMASCHINE							
									
Volt 400 kW 1,1									
hp	Rpm	m/s	dB	E	F	G	G1	kg	
1,5	2800	24	70	370	500	450	210	25	
									
Ø mm	P	R	T	Sm	J°				
Ø165xØ22	500	0	120	0+3	45°				



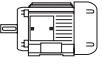
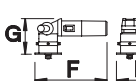

OPTIONAL
IWR-85
Insert for Radius

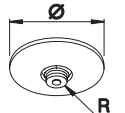





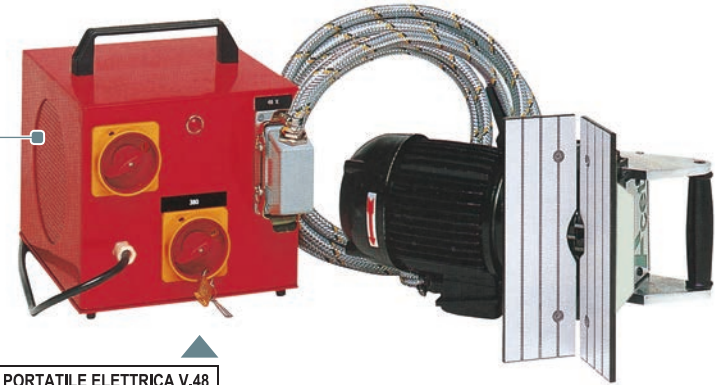

ART. 85		SMUSSATRICE PORTATILE ELETTRICA PORTABLE ELECTRIC CHAMFERING MACHINE CHANFREINEUSE PORTATIVE ELECTRIQUE ELEKTRISCHE ANFASMASCHINE											
													
Volt 230/1F Watt 1200						ISO TPMA 22.04.08							
hp	Rpm	m/s	E	F	G	dB	kg	Ø mm	Z	Ø	Rmin	Sm	J°
1,6	7000	18	210	330	160	70	6	50	3	120	12	0+8	45°

ELECTRIC TRANSFORMER

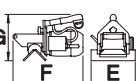

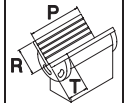



Volt 400 → Volt 48

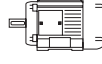

ART. 15		SMUSSATRICE PORTATILE ELETTRICA V.48 PORTABLE ELECTRIC CHAMFERING MAC. CHANFREINEUSE PORTATIVE ELECTRIQUE KANTENFRÄSMASCHINE TRAGBAR V.48										
												
Volt 400 → Volt 48 kW 0,75												
hp	Rpm	m/s	dB	E	F	G	kg					
1	2800	12	68	250	400	260	16					
												
ISO SPUN 12.03.08												
Ø mm	Z	P	R	T	Sm	J°						
80	20	250	80	80	0+20	15°+45°						

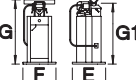

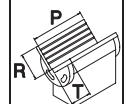
OPTIONAL
SMT
For tubes Ø min 140

ART. 19		SMUSSATRICE ELETTRICA A VOLT 48 CHAMFERING MACHINE VOLT 48 CHANFREINEUSE ELECTRIQUE VOLT 48 KANTENFRÄSMASCHINE STATIONÄR V.48										
												
Volt 400 → Volt 48 kW 0,75												
hp	Rpm	m/s	dB	E	F	G	G1	kg				
1	2800	12	68	600	600	1110	980	110				
												
ISO SPUN 12.03.08												
Ø mm	Z	P	R	T	Sm	J°						
80	20	250	80	80	0+20	15°+45°						
		500	80	80	0+6	15°+45°						



ART. 40
 SMUSSATRICE PORTATILE PNEUMATICA
 PORTABLE PNEUMATIC CHAMFERING MAC.
 CHANFREINEUSE PORTAT. PNEUMATIQUE
 PNEUMATISCHE HANDENTGRATMASCHINE

Bar 6 Lt/1' 320						
kW	Rpm	Rpm'	dB	G	F	kg
0,22	20000	12000	72	Ø95	250	3
Ø mm	Z	Sm	J°			
14	3	0+3	45°			



ART. 41
 SMUSSATRICE PORT. PNEUMATICA "MINI"
 PORTABLE PNEUMATIC CHAMFERING MAC.
 CHANFREINEUSE PORTAT. PNEUMATIQUE
 PNEUMATISCHE KANTENFRÄSMASCHINE

Bar 6 Lt/1' 200						
kW	Rpm	Rpm'	dB	G	F	kg
0,11	20000	12000	70	Ø50	170	0,8
Ø mm	Z	Sm	J°			
10	3	0+1	45°			

INCLUDED
 Milling cutter
 for ART.41



OPTIONAL
SB-40
 for ART.40

INCLUDED

OPTIONAL
 Milling cutters
 for ART.40



ART. 42
 SMUSSATRICE PORTATILE ELETTRICA
 PORTABLE ELECTRIC CHAMFERING MAC.
 CHANFREINEUSE PORTATIVE ELECTRIQUE
 ELEKTRISCHE ANFASMASCHINE

Volt 230/1F Watt 670							
hp	Rpm	m/s	dB	E	F	G	kg
0,9	11000	17	68	220	300	130	2
ISO SPMA 09.03.08							
Ø mm	Z	P	R	T	Sm	J°	
30	2	130	50	30	0+3	45°	

ART. 84
 SMUSSATRICE PORTATILE ELETTRICA
 PORTABLE ELECTRIC CHAMFERING MACHINE
 CHANFREINEUSE PORTATIVE ELECTRIQUE
 ELEKTRISCHE ANFASMASCHINE

Volt 230/1F Watt 1200			ISO SPMA 12.04.08											
hp	Rpm	m/s	E	F	G	dB	kg	Ø mm	Z	P	R	T	Sm	J°
1,6	7000	15	245	330	155	70	4,8	40	3	180	60	40	0+8	45°

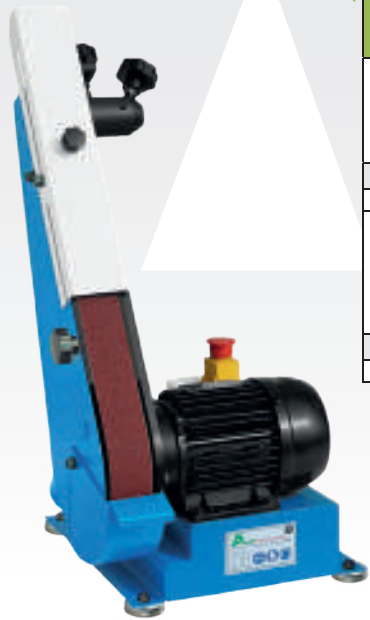

ART. 86		LEVIGATRICE A NASTRO DA BANCO BELT GRINDING MACHINE FOR DESK TANK DE BANC BANDSCHLEIFMASCHINE FÜR WERKBANK									
Volt 400 kW 1,1											
hp	Rpm	m/s	dB	F	E	G	G1	kg			
1,5	2800	30	68	370	580	690	290	30			
		OPTIONALS									
		Volt 230/1F									
A	B	C	D	Ø mm	INV.MF	BAS.01					
1250	50	300	60	Ø200x50xØ20	Rpm 0+3000	ASP.04					



ART. 87		LEVIGATRICE ORIENTABILE A NASTRO ORIENTABLE BELT GRINDING MACHINE TANK BANDSCHLEIFMASCHINE									
Volt 400 kW 1,1											
hp	Rpm	m/s	dB	F	E	G	G1	kg			
1,5	2800	30	68	450	750	1330	970	55			
		OPTIONALS									
		Volt 230/1F									
A	B	C	D	Ø mm	INV.MF	IA-1					
1250	50	300	60	Ø200x50xØ20	Rpm 0+3000	kW 0.55					

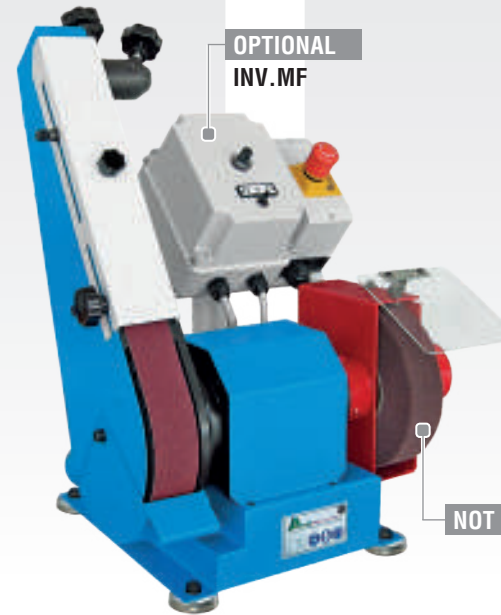

ART. 82		LEVIGATRICE A NASTRO + PULITRICE DA BANCO BELT GRINDING + POLISHING MACHINE FOR DESK TANK + POLISSOIR DE BANC BANDSCHLEIF-UND POLIERMASCHINE									
Volt 400 kW 1,1											
hp	Rpm	m/s	dB	F	E	G	G1	kg			
1,5	2800	30	72	490	580	690	290	39			
		NOT INCLUDED		Volt 230/1F							
A	B	C	D	Ø mm	Ø mm	INV.MF	BAS.01				
1250	50	300	60	Ø200x50xØ20	Ø200x50xØ20	Rpm 0+3000	ASP.04				



ART. 136		LEVIGATRICE A NASTRO + SMERIGLIATRICE BELT GRINDING + GRINDING MACHINE FOR DESK TANK + MEULE DE BANC BANDSCHLEIFM.-UND SCHEIBENSCHLEIFEIR									
Volt 400 kW 1,1											
hp	Rpm	m/s	dB	F	E	G	G1	kg			
1,5	2800	30	72	490	580	690	290	39			
		NOT INCLUDED		Volt 230/1F							
A	B	C	D	Ø mm	Ø mm	INV.MF	BAS.01				
1250	50	300	60	Ø200x50xØ20	Ø200x25xØ20	Rpm 0+3000	ASP.04				

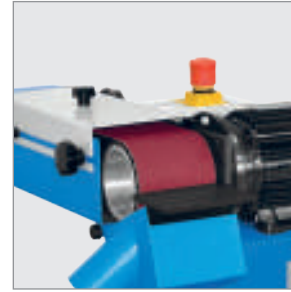
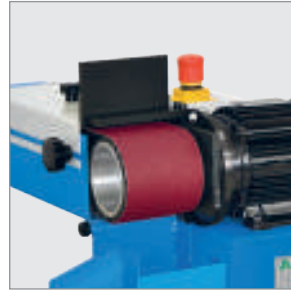
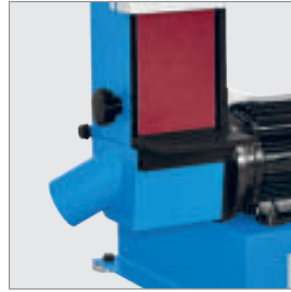

ART. 89		LEVIGATRICE A NASTRO + PULITRICE DA BANCO BELT GRINDING + POLISHING MACHINE FOR DESK TANK + POLISSOIR DE BANC BANDSCHLEIF-UND POLIERMASCHINE							
Volt 400 kW 1,1									
hp	Rpm	m/s	dB	F	E	G	G1	kg	
1,5	2800	15	72	600	550	640	230	34	
				OPTIONALS					
				NOT INCLUDED					
				Volt 230/1F					
A	B	C	D	Ø	Ø mm	INV.MF	BAS.01	ASP.04	
1000	100	290	100	100	Ø200x50xØ20	Rpm 0÷3000			

ART. 135		LEVIGATRICE A NASTRO + SMERIGLIATRICE BELT GRINDING + GRINDING MACHINE FOR DESK TANK + MEULE DE BANC BANDSCHLEIFM.-UND SCHEIBENSCHLEIFER							
Volt 400 kW 1,1									
hp	Rpm	m/s	dB	F	E	G	G1	kg	
1,5	2800	15	72	600	630	640	155	34	
				OPTIONALS					
				NOT INCLUDED					
				Volt 230/1F					
A	B	C	D	Ø	Ø mm	INV.MF	BAS.01	ASP.04	
1000	100	290	100	100	Ø200x25xØ20	Rpm 0÷3000			

ART. 22		LEVIGATRICE A NASTRO DA BANCO BELT GRINDING MACHINE FOR DESK TANK DE BANC BANDSCHLEIFMASCHINE FÜR WERKBANK							
Volt 400 kW 1,1									
hp	Rpm	m/s	dB	E	F	G	G1	kg	
1,5	2800	15	70	550	450	600	150	28	
				OPTIONALS					
A	B	C	D	Ø	BAS.01	ASP.04			
1000	100	290	100	100	kg 40	kg 45			

ART. 45		LEVIGATRICE ORIENTABILE A NASTRO ORIENTABLE BELT GRINDING MACHINE TANK SCHWENKBARE BANDSCHLEIFMASCHINE							
Volt 400 kW 1,1									
hp	Rpm	m/s	dB	E	F	G	G1	kg	
1,5	2800	15	70	520	650	1300	790	60	
				OPTIONALS					
A	B	C	D	Ø	IA-1				
1000	100	290	100	100	kW 0,55				





OPTIONAL
IA-1



COVER INCLUDED

OPTIONAL
SQT

OPTIONAL
IA-1

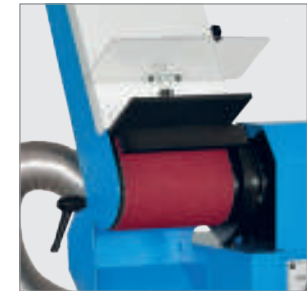
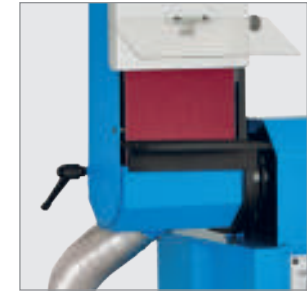

ART. 17		LEVIGATRICE ORIENTABILE A NASTRO ORIENTABLE BELT GRINDING MACHINE TANK BANDSCHLEIFMASCHINE									
Volt 400 kW 1,1											
hp	Rpm	m/s	dB	E	F	G	G1	kg			
1,5	2800	20	70	520	650	1500	880	75			
OPTIONALS											
A	B	C	D	Ø	IA-1						
1500	120	450	120	135	kW 0,55						

ART. 16		LEVIGATRICE ORIENTABILE A NASTRO ORIENTABLE BELT GRINDING MACHINE TANK BANDSCHLEIFMASCHINE									
Volt 400 kW 1,8											
hp	Rpm	m/s	dB	E	F	G	G1	kg			
2,5	1400 2800	10 20	70	600	700	1600	980	100			
OPTIONALS											
A	B	C	D	Ø	IA-1	SQT					
1500	120	470	120	135	kW 0,55	H=445 L=80					

ART. 07		LEVIGATRICE ORIENTABILE A NASTRO ORIENTABLE BELT GRINDING MACHINE TANK BANDSCHLEIFMASCHINE									
Volt 400 kW 1,8											
hp	Rpm	m/s	dB	E	F	G	G1	kg			
2,5	1400 2800	10 20	70	600	700	1750	980	110			
OPTIONALS											
A	B	C	D	Ø	IA-1	SQT					
1750	150	590	150	135	kW 0,55	H=570 L=80					

ART. 63		LEVIGATRICE ORIENTABILE A NASTRO ORIENTABLE BELT GRINDING MACHINE TANK BANDSCHLEIFMASCHINE									
Volt 400 kW 3											
hp	Rpm	m/s	dB	E	F	G	G1	kg			
4	1400 2800	10 20	70	600	750	1750	980	115			
OPTIONALS											
A	B	C	D	Ø	IA-1	SQT					
1750	200	590	200	135	kW 0,55	H=570 L=80					



OPTIONAL
IA-2



ART. 08		LEVIGATRICE DOPPIA ORIENT. A NASTRO DOUBLE ORIENTABLE BELT GRINDING MAC. TANK (2 POSTES) DOPPELBAND - SCHLEIFMASCHINE										
Volt 400 kW 1,8		hp	Rpm	m/s	dB	E	F	G	G1	kg		
2,5	1400	10	20	70	600	650	1600	980	145			
OPTIONALS												
A	B	C	D	∅	SQT		IA-2					
1500	120	470	120	135	H=445 L=80		kW 0,55					

ART. 06		LEVIGATRICE A NASTRO + SMERGLIATRICE BELT GRINDING + GRINDING MACHINE TANK + MEULE BANDSCHLEIFM.-UND SCHEIBENSCHLEIFER										
Volt 400 kW 1,8		hp	Rpm	m/s	dB	E	F	G	G1	kg		
2,5	1400	10	20	70	600	700	1600	980	115			
A	B	C	D	∅	∅ mm		IA-2					
1500	120	470	120	135	∅200x25x∅20		kW 0,55					

ART. 05		LEVIGATRICE A NASTRO + PULTRICE BELT GRINDING + POLISHING MACHINE TANK + POLISSOIR BANDSCHLEIF-UND POLIERMASCHINE										
Volt 400 kW 1,8		hp	Rpm	m/s	dB	E	F	G	G1	kg		
2,5	1400	10	20	70	600	900	1600	910	115			
A	B	C	D	∅	∅ mm		IA-2					
1500	120	470	120	135	∅250x∅25		kW 0,55					

ART. 127		LEVIGATRICE A NASTRO + PULTRICE BELT GRINDING + POLISHING MACHINE TANK + POLISSOIR BANDSCHLEIF-UND POLIERMASCHINE										
Volt 400 kW 4,4		hp	Rpm	m/s	dB	E	F	G	G1	kg		
6	1400	10	20	70	600	920	1750	910	170			
A	B	C	D	∅	∅ mm		IA-2					
1750	200	590	200	135	∅300x∅35		kW 0,55					





OPTIONAL
NAS-20
NAS-40



ART. 170		LEVIGATRICE DOPPIA ORIENT. A NASTRO DOUBLE ORIENTABLE BELT GRINDING MAC. TANK (2 POSTES) DOPPELBAND - SCHLEIFMASCHINE									
Volt 400 kW 4,4											
hp	Rpm	m/s	dB	E	F	G	G1	kg			
6	1400 2800	10 20	70	600	750	1750	980	220			
OPTIONALS											
A	B	C	D	Ø	SQT		IA-2				
1750	200	590	200	135	H=570 L=80		kW 0,55				

ART. 35		LEVIGATRICE A NASTRO VERTICALE VERTICAL BELT GRINDING MACHINE TANK VERTICAL VERTIKAL BANDSCHLEIFMASCHINE											
Volt 400 kW 0,8													
hp	Rpm	m/s	dB	E	F	G	G1	kg	A	B	C	D	J°
1	1400 2800	9 18	70	600	700	1400	940	100	1700	25-40	280	300	-20°+60°
OPTIONALS													
OPTIONAL: NAS-20				OPTIONAL: NAS-40									
Ø	C	D	A	B	Ø	C	D	A	B	INVERTER		IA-1	
30	120	32	2050	20	30	120	60	2050	40	Rpm 0+3000		kW 0,55	

ART. 131		LEVIGATRICE A NASTRO BELT GRINDING MACHINE TANK BANDSCHLEIFMASCHINE											
Volt 400 kW 0,8													
hp	Rpm	m/s	dB	E	F	G	G1	kg					
1	1400 2800	18 36	70	600	1100	1400	940	110					
OPTIONALS													
A	B	Ø mm		INV.		IA-2							
2250	50	Ø250x50xØ35		Rpm 0+3000		kW 0,55							



ART. 67		LEVIGATRICE ORIENTABILE A NASTRO ORIENTABLE BELT GRINDING MACHINE BACKSTAND SCHWENKBARE BANDSCHLEIFMASCHINE							
Volt 400 kW 3									
hp	Rpm	m/s	dB	E	F	G	G1	kg	
4	2800	30	73	1100	550	1000	840	90	
A	B	C	D	Ø	OPTIONAL IA-1				
2000	75	605	100	200	kW 0,55				

ART. 33		LEVIGATRICE ORIENTABILE A NASTRO ORIENTABLE BELT GRINDING MACHINE BACKSTAND SCHWENKBARE BANDSCHLEIFMASCHINE							
Volt 400 kW 3,7									
hp	Rpm	m/s	dB	E	F	G	G1	kg	
5	1400 2800	18 36	75	1100	700	1150	830	150	
A	B	C	D	Ø	OPTIONAL IA-2				
2000	75	470	100	250	kW 0,55				







ART. 38		LEVIGATRICE ORIENTABILE A NASTRO ORIENTABLE BELT GRINDING MACHINE BACKSTAND SCHWENKBARE BANDSCHLEIFMASCHINE							
Volt 400 kW 3,7									
hp	Rpm	m/s	dB	E	F	G	G1	kg	
5	1400 2800	18 36	75	1100	700	1150	830	180	
A	B	C	D	Ø	OPTIONAL IA-2				
2000	150	470	180	250	kW 0,55				



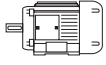

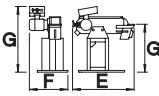

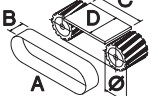



**ART.
90**

LEVIGATRICE ORIENTABILE A NASTRO
ORIENTABLE BELT GRINDING MACHINE
BACKSTAND
SCHWENKBARE BANDSCHLEIFMASCHINE

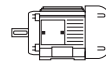
														
Volt 400 kW 4,5			kg		OPTIONAL									
hp	Rpm	m/s	dB	E	F	G	G1	kg	A	B	C	D	Ø	ASP.01
7	1400 2800	18 36	75	1420	700	1150	830	220	2500	200	720	230	250	kW 1,5

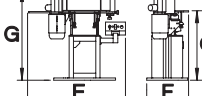
**ART.
73 N**

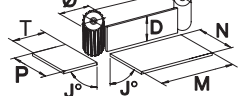
LEVIGATRICE FRONTALE
FRONTAL BELT GRINDING MACHINE
PONCEUSE FRONTAL
STIRN-BANDSCHLEIFMASCHINE

																		
Volt 400 kW 3			kg			OPTIONAL												
hp	Rpm	m/s	dB	E	F	G	G1	kg	A	B	Ø	D	M	N	P	T	J°	ASP.01
4	1400 2800	10 20	70	1050	550	1200	910	225	1750	200	135	200	565	300	565	300	-45°/+45°	kW 1,5











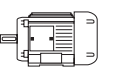



ART. 64		LEVIGATRICE A NASTRO PROFESSIONAL PROFESSIONAL BELT GRINDING MACHINE BACKSTAND PROFESSIONNELLE BERUFLICHE BANDSCHLEIFMASCHINE												
	Volt 400 kW 4,5													
hp	Rpm	m/s	E	F	G	G1	dB	kg	A	B	C	D	Ø	OPTIONAL ASP.01
6	1400 2800	15 30	720	1390	1020	900	70	290	2500	300	900	300	200	kW 1,5

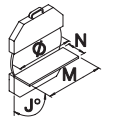
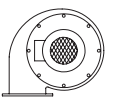

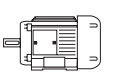



ART. 59		LEVIGATRICE A NASTRO PROFESSIONAL PROFESSIONAL BELT GRINDING MACHINE BACKSTAND PROFESSIONNELLE BERUFLICHE BANDSCHLEIFMASCHINE												
	Volt 400 kW 5,2													
hp	Rpm	m/s	E	F	G	G1	dB	kg	A	B	C	D	Ø	OPTIONAL ASP.01
7	700 1400	9 18	1100	1700	1100	890	75	500	3100	500	1000	550	250	kW3

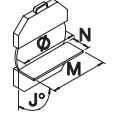
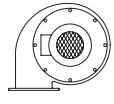

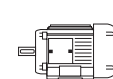



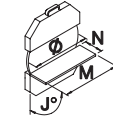
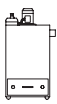

ART. 24		LEVIGATRICE A DISCO GRINDING DISK-MACHINE LAPIDAIRE TELLERSCHLEIFMASCHINE							
									
Volt 400 kW 1,8									
hp	Rpm	m/s	dB	E	F	G	G1	kg	
2,5	1400 2800	30 60	70	600	800	1300	920	105	
									
Ø	M	N	J°	IA-1					
400	450	230	0°±90°	kW 0,55					





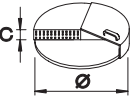

ART. 62		LEVIGATRICE A DISCO GRINDING DISK-MACHINE LAPIDAIRE TELLERSCHLEIFMASCHINE							
									
Volt 400 kW 3									
hp	Rpm	m/s	dB	E	F	G	G1	kg	
4	950	30	68	700	800	1360	900	135	
									
Ø	M	N	J°	IA-1					
600	650	230	0°±90°	kW 0,55					

ART. 52		LEVIGATRICE A DISCO GRINDING DISK-MACHINE LAPIDAIRE TELLERSCHLEIFMASCHINE							
									
Volt 400 kW 4									
hp	Rpm	m/s	E	F	G	G1	dB	kg	
5,5	950	40	1300	1000	1450	870	70	370	
									
Ø	M	N	J°	ASP.01					
800	1000	300	-45°±+45°	kW 1,5					

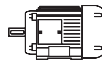

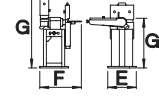

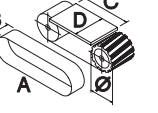
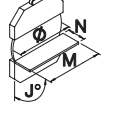
ART. 98 LEVIGATRICE A DISCO ORIZZONTALE HORIZONTAL GRINDING DISK-MACHINE LAPIDAIRE HORIZONTALE HORIZONTAL TELLERSCHLEIFMASCHINE									
									
Volt 400 kW 3									
hp	Rpm	m/s	dB	E	F	G	G1	kg	
4	950	30	68	850	650	970	880	130	
									
OPTIONAL ASP.03 kW 0,75		Ø				C			
		600				80			

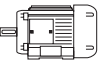

OPTIONAL
IA-2

ART. 99 LEVIG. A NASTRO + LEVIGATRICE A DISCO BELT GRINDING + GRINDING DISK-MACHINE TANK + LAPIDAIRE BANDSCHLEIF-UND TELLERSCHLEIFMASC.									
									
Volt 400 kW 4									
hp	Rpm	m/s	dB	E	F	G	G1	kg	
5,5	700 1400	5 10	75	600	880	1750	980	240	
									
OPTIONAL		OPTIONAL		OPTIONAL					
A	B	C	D	Ø	Ø	M	N	J°	IA-2
1750	200	590	200	135	600	650	230	0°-90°	kW 0,55

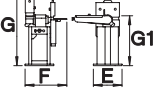

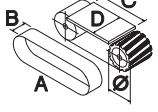
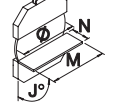
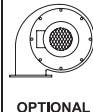
ART. 21 LEVIG. A NASTRO + LEVIGATRICE A DISCO BELT GRINDING + GRINDING DISK-MACHINE TANK + LAPIDAIRE BANDSCHLEIF-UND TELLERSCHLEIFMASC.									
									
Volt 400 kW 1,8									
hp	Rpm	m/s	dB	E	F	G	G1	kg	
2,5	1400 2800	10 20	70	600	800	1600	980	145	
									
OPTIONAL		OPTIONAL		OPTIONAL					
A	B	C	D	Ø	Ø	M	N	J°	IA-2
1500	120	470	120	135	400	450	230	0°-90°	kW 0,55



OPTIONAL
IA-2

ART. 30		LEVIGATRICE TEDESC. + LEVIGAT. A DISCO TELESCOPIC + GRINDING DISK-MACHINE TANK TÉLESCOPIQUE + LAPIDAIRE TELESKOPBAND-UND TELLERSCHLEIFMAS.						
Volt 400 kW 1,8								
hp	Rpm	m/s	dB	E	F	G	G1	kg
2,5	1400 2800	15 30	70	600	900	1850	910	150
Ø mm				A		B		
Ø200x50xØ20				2000+2500		50		
				OPTIONAL				
Ø	M	N	J°	IA-2				
400	450	230	0°+90°	kW 0,55				



ART. 26		LEVIGATRICE A DISCO + PULITRICE GRINDING DISK-MACHINE + POLISHING MAC. LAPIDAIRE + POLISSOIR TELLERSCHLEIF-UND POLIERMACHINE						
Volt 400 kW 1,8								
hp	Rpm	m/s	dB	E	F	G	G1	kg
2,5	1400 2800	18 36	70	600	1000	1300	910	120
				NOT INCLUDED		OPTIONAL		
Ø	M	N	J°	Ø mm		IA-2		
400	450	230	0°+90°	Ø250xØ25		kW 0,55		



ART. 31		LEVIG. A NASTRO + LEVIG. TELESCOPICA BELT GRINDING + TELESCOPIC GRINDING M. TANK + TANK TÉLESCOPIQUE TELESKOPBAND-UND BANDSCHLEIFMASC.						
Volt 400 kW 1,8								
hp	Rpm	m/s	dB	E	F	G	G1	kg
2,5	1400 2800	15 30	70	600	800	1850	910	150
A B C D Ø				Ø mm		A B		
1500	120	470	120	135	Ø200x50xØ20		2000+2500 50	

ART. 32									
LEVIGATRICE TELESCOPICA + PULITRICE TELESCOPIC GRINDING + POLISHING MAC. TANK TÉLESCOPIQUE + POLISSOIR TELESKOPBAND-UND POLIERMASCHINE									
Volt 400 kW 1,8									
hp	Rpm	m/s	dB	E	F	G	G1	kg	
2,5	1400 2800	15 30	70	600	1000	1850	910	115	
Ø mm		A		B		Ø mm		IA-2	
Ø200x50xØ20		2000+2500		50		Ø250xØ25		kW 0,55	



OPTIONAL
IA-2



ART. 23									
SMUSSATRICE + LEVIGATRICE TEDESC. CHAMFERING + TELESCOPIC GRINDING M. CHANFREINEUSE + TANK TÉLESCOPIQUE KANTENFRÄS UND TELESKOP-BANDSCHL.									
Volt 400 kW 1,8									
hp	Rpm	m/s	dB	E	F	G	G1	kg	
2,5	1400 2800	15 30	70	600	700	1850	910	120	
Ø mm		A		B		Ø mm		IA-1	
Ø200x50xØ20		2000+2500		50		Ø200x25xØ20		kW 0,55	



ART. 34									
LEVIG. TELESCOPICA + SMERIGLIATRICE TELESCOPIC GRINDING + GRINDING MAC. TANK TÉLESCOPIQUE + MEULE TELESKOPBAND-UND SCHEIBENSCHLEIFM.									
Volt 400 kW 1,8									
hp	Rpm	m/s	dB	E	F	G	G1	kg	
2,5	1400 2800	15 30	70	600	800	1850	910	115	
Ø mm		A		B		Ø mm		IA-2	
Ø200x50xØ20		2000+2500		50		Ø200x25xØ20		kW 0,55	







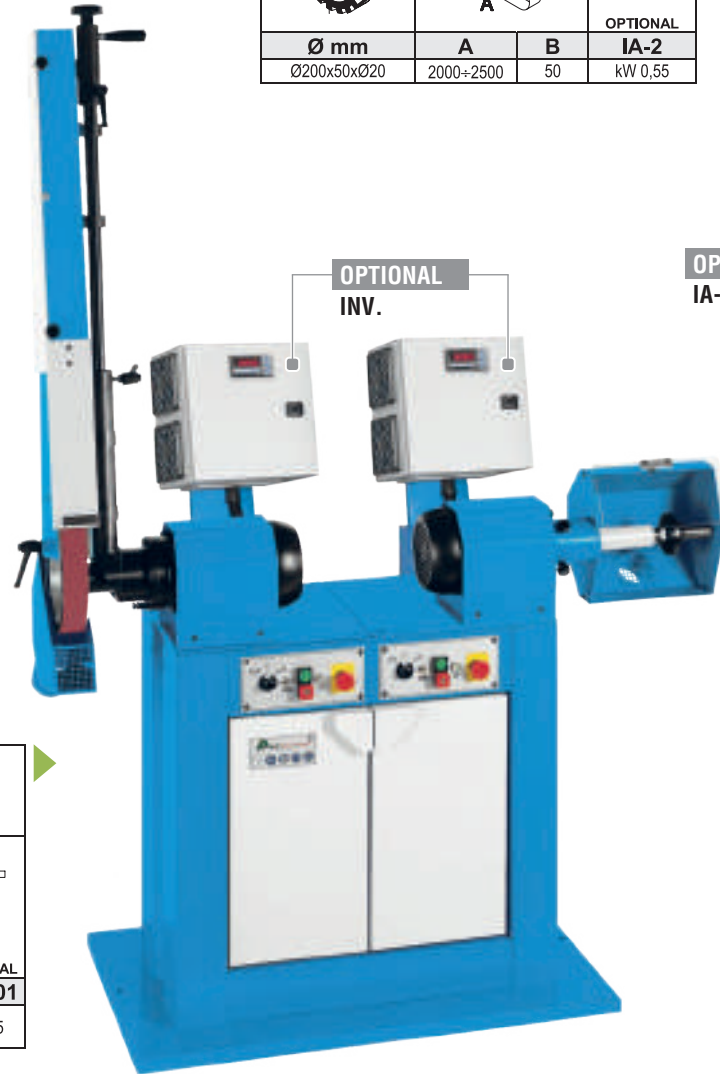

ART. 28		LEVIGATRICE A NASTRO TELESCOPICA TELESCOPIC BELT GRINDING MACHINE TANK TÉLESCOPIQUE TELESKOP-BANDSCHLEIFMASCHINE								
Volt 400 kW 1,8										
hp	Rpm	m/s	dB	E	F	G	G1	kg		
2,5	1400 2800	15 30	70	600	800	1850	910	110		
								OPTIONAL		
Ø mm		A	B	IA-1						
Ø200x50xØ20		2000+2500	50	kW 0,55						

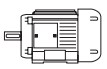
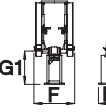

ART. 29		LEVIGATRICE A NASTRO DOPPIA TEDESC. DOUBLE TELESCOPIC BELT GRINDING MAC. TANK (2 POSTES) TÉLESCOPIQUE DOPPELTELESKOP-BANDSCHLEIFMASC.								
Volt 400 kW 1,8										
hp	Rpm	m/s	dB	E	F	G	G1	kg		
2,5	1400 2800	15 30	72	600	850	1850	910	150		
								OPTIONAL		
Ø mm		A	B	IA-2						
Ø200x50xØ20		2000+2500	50	kW 0,55						

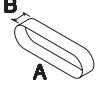

ART. 68		LEVIGATRICE ORIENTABILE A NASTRO TELESCOPICA + PULITRICE TELESCOPIC ORIENTABLE BELT GRINDING + POLISHING MACHINE TANK TÉLESCOPIQUE + POLISSOIR TELESKOPBAND-UND POLIERMASCHINE																			
Nr.2 Volt 400 kW 1,8																					
hp	Rpm	m/s	E	F	G	G1	dB	kg	A	B	Ø mm	Ø mm	OPTIONAL	OPTIONAL							
2,5	1400 2800	15 30	600	1500	1850	910	70	240	2000+2500	50	Ø200x50xØ20	Ø250xØ25	INVERTER	ASP.01							
											Rpm 0+3000	kW 1,5									

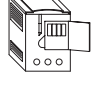
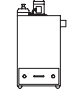

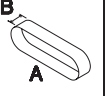
ART. 57		LEVIGATRICE PROFESSIONAL DOPPIA ORIENTABILE A NASTRO TELESCOPICA PROFESSIONAL DOUBLE TELESCOPIC ORIENTABLE BELT GRINDING MACHINE TANK (2 POSTES) TÉLESCOPIQUE PROFESSIONNEL DOPPELTELESKOP-BANDSCHLEIFMASCHINE													
															
Volt 400 kW 4,4		G1	F	G	G1	dB	kg	A	B	STANDARD	OPTIONAL	OPTIONAL	OPTIONAL		
hp	Rpm	m/s	E	F	G	G1	dB	kg	A	B	Ø mm	Ø mm	INVERTER	ASP.01	
6	1400 2800	18 36	600	1100	2200	880	75	260	2500+3000	50	Ø250x50xØ35	Ø250x75-100	Rpm 0+3000	kw 1,5	

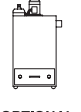
ART. 58		LEVIGATRICE PROFESSIONAL DOPPIA ORIENTABILE A NASTRO TELESCOPICA PROFESSIONAL DOUBLE TELESCOPIC ORIENTABLE BELT GRINDING MACHINE TANK (2 POSTES) TÉLESCOPIQUE PROFESSIONNEL DOPPELTELESKOP-BANDSCHLEIFMASCHINE													
															
Nr.2 Volt 400 kW 4,4		G1	F	G	G1	dB	kg	A	B	STANDARD	OPTIONAL	OPTIONAL	OPTIONAL		
hp	Rpm	m/s	E	F	G	G1	dB	kg	A	B	Ø mm	Ø mm	INVERTER	ASP.01	
6	1400 2800	18 36	600	1670	2200	880	75	365	2500+3000	50	Ø250x50xØ35	Ø250x75-100	Rpm 0+3000	kw 1,5	



ART. 72		LEVIGATRICE PROFESSIONAL ORIENTABILE A NASTRO TELESCOPICA + PULTRICE PROFESSIONAL PROFESSIONAL TELESCOPIC ORIENTABLE BELT GRINDING + PROFESSIONAL POLISHING MACHINE TANK TÉLESCOPIQUE PROFESSIONNEL + POLISSOIR PROFESSIONNEL TELESKOPBAND-UND POLIERMASCHINE												
Volt 400 kW 4,4		G1	F	G	G1	dB	kg	A	B	OPTIONAL	Ø mm	INVERTER	ASP.01	
6	1400 2800	18 36	600	1100	2200	880	70	200	2500+3000	50	Ø250x75-100	Ø300xØ35	Rpm 0+3000	kW 1,5

ART. 70		LEVIGATRICE PROFESSIONAL ORIENTABILE A NASTRO TELESCOPICA + PULTRICE PROFESSIONAL PROFESSIONAL TELESCOPIC ORIENTABLE BELT GRINDING + PROFESSIONAL POLISHING MACHINE TANK TÉLESCOPIQUE PROFESSIONNEL + POLISSOIR PROFESSIONNEL TELESKOPBAND-UND POLIERMASCHINE												
Nr.2 Volt 400 kW 4,4		G1	F	G	G1	dB	kg	A	B	OPTIONAL	Ø mm	INVERTER	ASP.01	
6	1400 2800	18 36	600	1650	2200	880	73	295	2500+3000	50	Ø250x75-100	Ø300xØ35	Rpm 0+3000	kW 1,5



OPTIONAL

INV.

- Inverter per la regolazione elettronica da 0 a 3000 giri/min
- Inverter for the electronic adjustment from 0 to 3000 Rpm
- Variateur pour le réglage électronique de 0 à 3000 T/min
- Inverter für stufenlose elektronische Regulierung von 0 bis 3000 UpM



OPTIONAL
IA-2







ART. 66		PULTRICE SINGOLA SINGLE POLISHING MACHINE POLISSOIR CHAQUE SCHLEIF-UND POLIERMASCHINE							
Volt 400 kW 1,8									
hp	Rpm	m/s	dB	E	F	G1	L	kg	
2,5	1400 2800	18 36	70	600	950	910	350	80	
NOT INCLUDED	OPTIONAL	OPTIONAL							
Ø mm	INVERTER	IA-1							
Ø250xØ25	Rpm 0÷3000	kW 0,55							



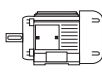
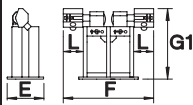

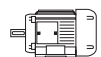

ART. 74		PULTRICE PROFESSIONAL SINGOLA PROFESS. SINGLE POLISHING MACHINE POLISSOIR PROFESSIONNEL CHAQUE SCHLEIF-UND POLIERMASCHINE							
Volt 400 kW 4,4									
hp	Rpm	m/s	dB	E	F	G1	L	kg	
6	1400 2800	22 44	70	600	950	890	370	90	
NOT INCLUDED	OPTIONAL	OPTIONAL							
Ø mm	Rpm	INVERTER	IA-1						
Ø300xØ35	700÷1400	Rpm 0÷3000	kW 0,55						

ART. 27		PULTRICE DOPPIA DOUBLE POLISHING MACHINE POLISSOIR (2 POSTES) DOPPELSCHLEIF-UND POLIERMASCHINE							
Volt 400 kW 1,8									
hp	Rpm	m/s	dB	E	F	G1	L	kg	
2,5	1400 2800	18 36	70	600	1000	910	300	85	
NOT INCLUDED	OPTIONAL	OPTIONAL							
Ø mm	INVERTER	IA-2							
Ø250xØ25	Rpm 0÷3000	kW 0,55							

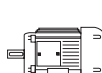
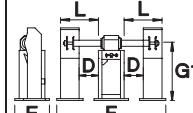



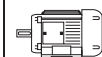

ART. 46		PULTRICE PROFESSIONAL DOPPIA PROFESS. DOUBLE POLISHING MACHINE POLISSOIR (2 POSTES) PROFESSIONNEL DOPPELSCHLEIF-UND POLIERMASCHINE							
Volt 400 kW 4,4									
hp	Rpm	m/s	dB	E	F	G1	L	kg	
6	1400 2800	22 44	70	600	1050	890	320	105	
NOT INCLUDED	OPTIONAL	OPTIONAL							
Ø mm	Rpm	INVERTER	IA-2						
Ø300xØ35	700÷1400	Rpm 0÷3000	kW 0,55						

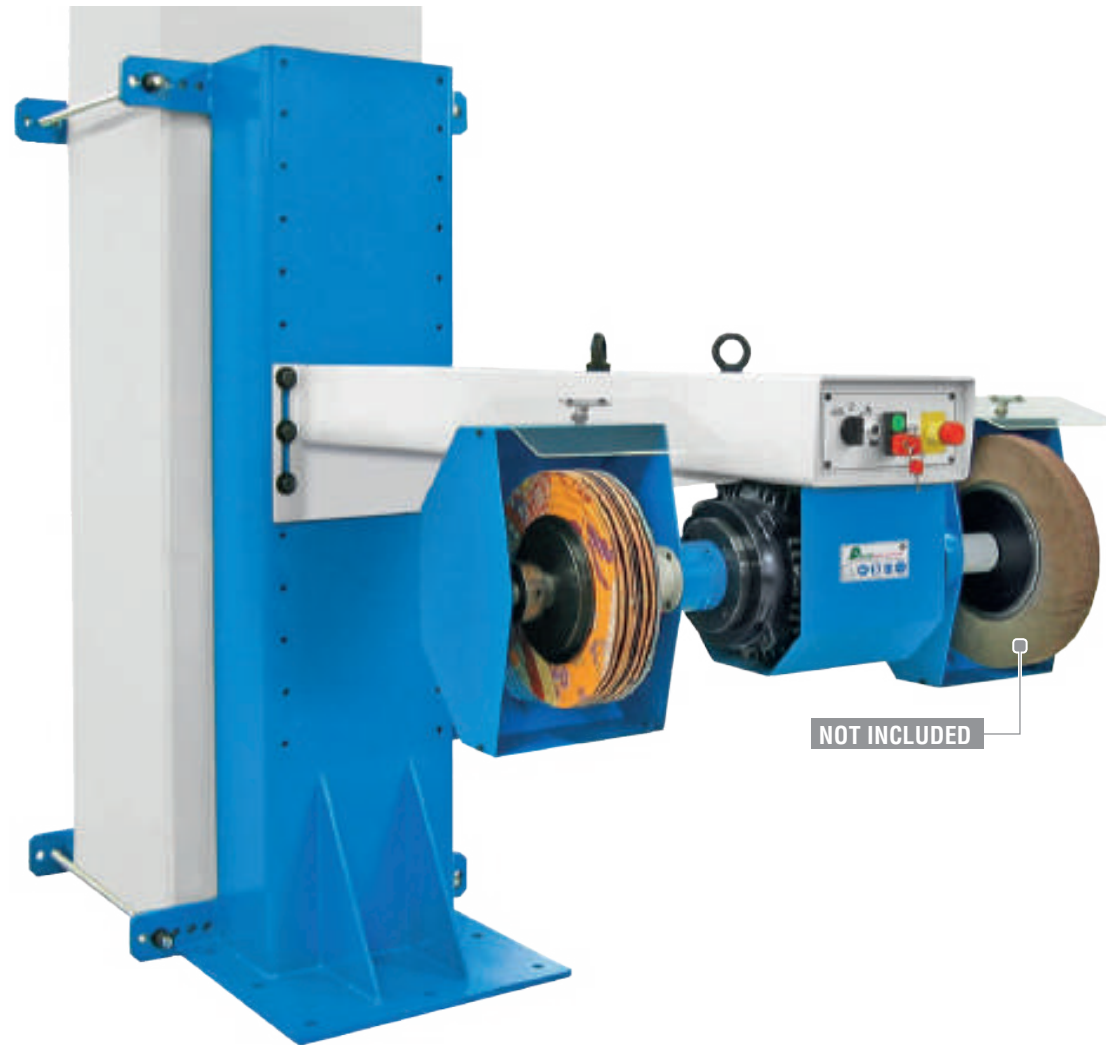

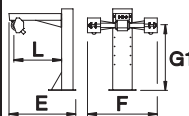





ART. 71		PULTRICE PROFESSIONAL DOPPIA PROFESSIONAL DOUBLE POLISHING MACHINE POLISSOIR (2 POSTES) PROFESSIONNEL DOPPELSCHLEIF-UND POLIERMASCHINE										
												
Nr.2 Volt 400 kW 4,4					kg	NOT INCLUDED	OPTIONAL	OPTIONAL	OPTIONAL			
hp	Rpm	m/s	E	F	G1	L	dB	kg	Ø mm	Rpm	INVERTER	ASP.01
6	1400 2800	22 44	600	1600	890	350	70	250	Ø300xØ35	700÷1400	Rpm 0÷3000	kW 1,5



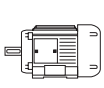

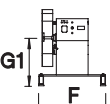

ART. 94		PULTRICE PROFESSIONAL DOPPIA PROFESSIONAL DOUBLE POLISHING MACHINE POLISSOIR (2 POSTES) PROFESSIONNEL DOPPELSCHLEIF-UND POLIERMASCHINE											
													
Volt 400 kW 5,5					kg	NOT INCLUDED	OPTIONAL	OPTIONAL	OPTIONAL				
hp	Rpm	m/s	E	F	G1	D	L	dB	kg	Ø mm	Rpm	INVERTER	ASP.01
7,5	1400 2800	29 58	600	1700	890	300	590	70	265	Ø400xØ35	700÷1400	Rpm 0÷3000	kW 1,5

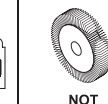
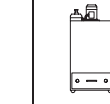

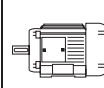
ART. 95		PULITRICE SOSPESA PROFESSIONAL PROFESSIONAL SUSPENDED POLISHING MACHINE POLISSOIR SUSPENDUE PROFESSIONNEL BERUFLICHE HÄNGEND POLIERMASCHINE										
												
Volt 400 kW 5,5						kg	NOT INCLUDED	OPTIONAL	OPTIONAL	OPTIONAL		
hp	Rpm	m/s	E	F	G1	L	dB	kg	Ø mm	Rpm	INVERTER	ASP.01
7,5	1400 2800	29 58	1450	1050	430+1500	1000	70	425	Ø400xØ35	700+1400	Rpm 0+3000	kW 1,5

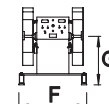

ART. 139		PULITRICE PROFESSIONAL SINGOLA CON 1 INVERTER PROFESSIONAL SINGLE POLISHING MACHINE WITH 1 INVERTER POLISSOIR CHAQUE PROFESSIONNEL AVEC 1 VARIATEUR DE VITESSE SCHLEIF-UND POLIERMASCHINE MIT 1 FREQUENZUMRICHTER								
										
Nr.1 Volt 400 kW 5,5										
hp	Rpm	E	F	G	G1	dB	kg	Ø mm	ASP.01	
7,5	0 + 1500	1460	1560	1600	1000	75	1050	Ø960 x 100 x Ø45	kW 3	

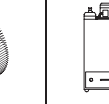
ART. 140		PULITRICE PROFESSIONAL DOPPIA CON 2 INVERTER PROFESSIONAL DOUBLE POLISHING MACHINE WITH 2 INVERTERS POLISSOIR (2 POSTES) PROFESSIONNEL AVEC 2 VARIATEURS DE VITESSE DOPPELSCHLEIF-UND POLIERMASCHINE MIT 2 FREQUENZUMRICHTER								
										
Nr.2 Volt 400 kW 5,5										
hp	Rpm	E	F	G	G1	dB	kg	Ø mm	ASP.01	
7,5	0 + 1500	1460	1560	1600	1000	75	1150	Ø960 x 100 x Ø45	kW 3	



ART. 132		PULTRICE DA BANCO POLISHING MACHINE FOR DESK POLISSOIR DE BANC POLIERMASCHINE FÜR WERKBANK									
Volt 400 kW 1,1											
hp	Rpm	m/s	dB	E	F	G	G1	kg			
1,5	2800	30	69	590	350	300	175	28			
		OPTIONALS									
NOT INCLUDED											
Ø mm		Volt 230/1F									
Ø200x50xØ20		INV.MF	BAS.01								
		Rpm 0+3000	ASP.04								

ART. 133		SMERIGLIATRICE DA BANCO GRINDING MACHINE FOR DESK MEULE DE BANC SCHEIBENSCHLEIFMASC. FÜR WERKBANK									
Volt 400 kW 1,1											
hp	Rpm	m/s	dB	E	F	G	G1	kg			
1,5	2800	30	69	590	440	300	155	28			
		OPTIONALS									
NOT INCLUDED											
Ø mm		Volt 230/1F									
Ø200x25xØ20		INV.MF	BAS.01								
		Rpm 0+3000	ASP.04								

ART. 134		SMERIGLIATRICE + PULTRICE DA BANCO GRINDING MACHINE + POLISHING MACHINE MEULE + POLISSOIR DE BANC SCHEIBENSCHLEIF-UND POLIERMASCHINE									
Volt 400 kW 1,1											
hp	Rpm	m/s	dB	E	F	G	G1	kg			
1,5	2800	30	69	590	440	300	155	28			
		OPTIONALS									
NOT INCLUDED											
Ø mm		Volt 230/1F									
Ø200x25xØ20		INV.MF	BAS.01								
		Rpm 0+3000	ASP.04								

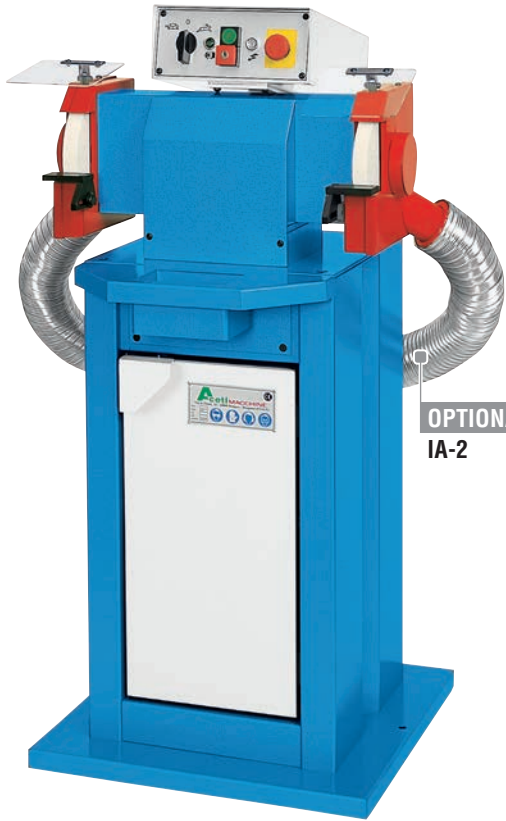

ART. 105 SMERIGLIATRICE GRINDING MACHINE TOURET A 2 MEULES SCHEIBENSCHLEIFMASCHINE										
Volt 400 kW 1,1										
hp	Rpm	m/s	dB	E	F	G	G1	kg		
1,5	1400 2800	15 30	69	610	650	1200	930	110		
Ø mm				OPTIONAL						
Ø200x25xØ20				IA-2 kW 0,55						

ART. 106 SMERIGLIATRICE GRINDING MACHINE TOURET A 2 MEULES SCHEIBENSCHLEIFMASCHINE										
Volt 400 kW 1,5										
hp	Rpm	m/s	dB	E	F	G	G1	kg		
2	1400	18	69	610	710	1200	930	115		
Ø mm				OPTIONAL						
Ø250x30xØ25				IA-2 kW 0,55						

ART. 107 SMERIGLIATRICE GRINDING MACHINE TOURET A 2 MEULES SCHEIBENSCHLEIFMASCHINE										
Volt 400 kW 1,8										
hp	Rpm	m/s	dB	E	F	G	G1	kg		
2,5	1400	22	69	610	720	1200	930	130		
Ø mm				OPTIONAL						
Ø300x35xØ30				IA-2 kW 0,55						





ART. 108 SMERIGLIATRICE + PULTRICE GRINDING MACHINE + POLISHING MACHINE MEULE + POLISSOIR SCHEIBENSCHLEIF-UND POLIERMASCHINE										
Volt 400 kW 1,1										
hp	Rpm	m/s	dB	E	F	G	G1	kg		
1,5	1400 2800	15 30	70	610	850	1200	930	115		
Ø mm				NOT INCLUDED			OPTIONAL			
Ø200x25xØ20				Ø200xØ20			IA-2 kW 0,55			

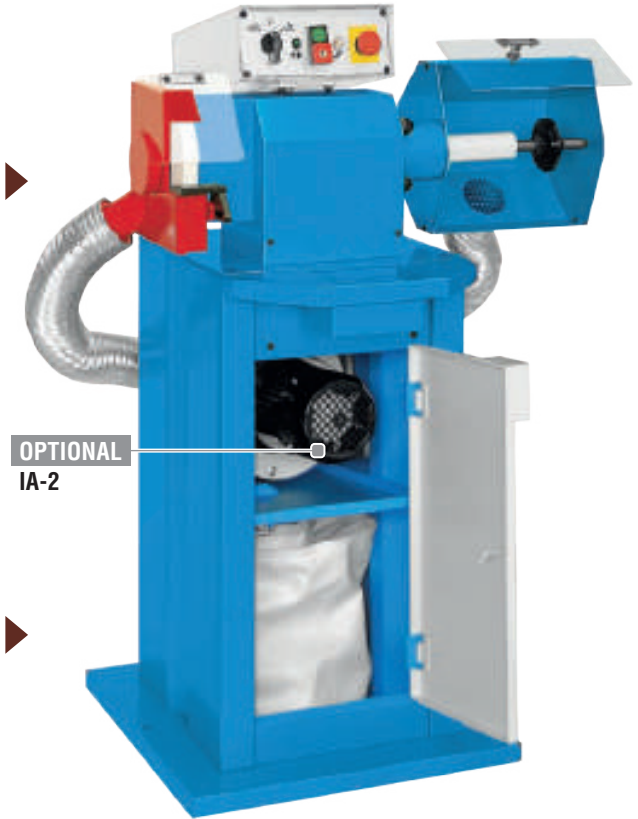



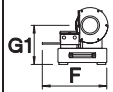
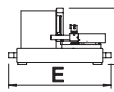

ART. 109 SMERIGLIATRICE + PULTRICE GRINDING MACHINE + POLISHING MACHINE MEULE + POLISSOIR SCHEIBENSCHLEIF-UND POLIERMASCHINE										
Volt 400 kW 1,5										
hp	Rpm	m/s	dB	E	F	G	G1	kg		
2	1400	18	70	610	900	1200	930	120		
Ø mm				NOT INCLUDED			OPTIONAL			
Ø250x30xØ25				Ø250xØ25			IA-2 kW 0,55			

ART. 110 SMERIGLIATRICE + PULTRICE GRINDING MACHINE + POLISHING MACHINE MEULE + POLISSOIR SCHEIBENSCHLEIF-UND POLIERMASCHINE										
Volt 400 kW 1,8										
hp	Rpm	m/s	dB	E	F	G	G1	kg		
2,5	1400	22	71	610	900	1200	930	130		
Ø mm				NOT INCLUDED			OPTIONAL			
Ø300x35xØ30				Ø300xØ30			IA-2 kW 0,55			

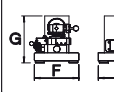
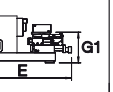



ART. 119													
AFFILAFRESE DA BANCO Ø6+32 MILLERS SHARPENING MACHINE FOR DESK Ø6+32 AFFÛTEUSE DE FRAISES DE BANC Ø6+32 FRÄSERSCHLEIFMASCHINE FÜR DIE WERKBANK Ø6+32													
 Volt 230/1F Watt 150													
hp	Rpm	m/s	E	F	G	G1	dB	kg	Ø mm	β°	Ø mm	MORSE	BAS.01
0,20	2800	22	530	370	300	200	72	30	Ø6+32	±5°	Ø150x2,3xØ20	Nr.3	kg 40

ART. 113														
AFFILAPUNTE DA BANCO Ø3+20 DRILLS SHARPENING MACHINE Ø3+20 AFFÛTEUSE DE FORÈTS DE BANC Ø3+20 SPIRALBOHRER-SCHLEIFMASCHINE Ø3+20														
 Volt 230/1F Watt 93									OPTIONALS					
hp	Rpm	m/s	E	F	G	G1	dB	kg	Ø mm	α°	Ø mm	Ø mm	Ø mm	
0,12	10 000	21	490	240	240	155	72	20	Ø3+20	50°-150°	Ø40x40xM10	Ø40x40xM10	Ø40x40xM10	



ART. 100 AFFILAPUNTE Ø5+35 + SMERIGLIATRICE
DRILLS SHARPENING + GRINDING M. Ø5+35
AFFÛTEUSE DE FORÈTS Ø5+35 + MEULE
SPIRALBOHRER UND SCHEIBENSCHLEIFM.

Volt 400 kW 1,8								
hp	Rpm	m/s	dB	E	F	G	G1	kg
2,5	1400 2800	15 30	70	650	950	1300	1030	110
				OPTIONAL				
Arm A	α°	Ø mm	Nr.	Ø mm	IA-2			
Ø5+35	118°	Ø200x25xØ20	1	Ø200x40xØ20	kW 0,55			

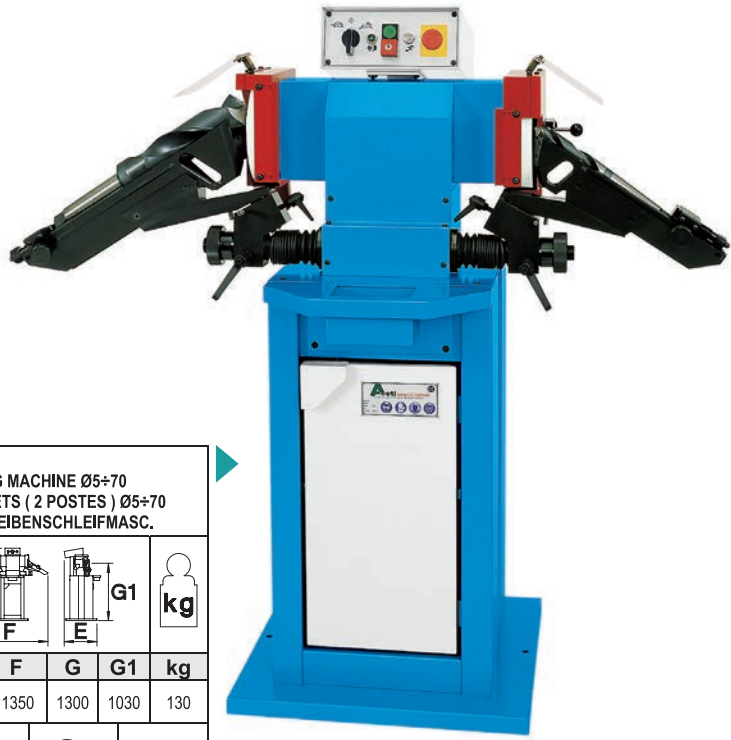

ART. 101 AFFILAPUNTE Ø5+70
DRILLS SHARPENING MACHINE Ø5+70
AFFÛTEUSE DE FORÈTS (2 POSTES) Ø5+70
SPIRALBOHRER SCHEIBENSCHLEIFMASC.

Volt 400 kW 1,8								
hp	Rpm	m/s	dB	E	F	G	G1	kg
2,5	1400 2800	15 30	70	700	1350	1300	1030	130
				OPTIONAL				
Arm A	Arm B	α°	Ø mm	D-AFF	IA-2			
Ø5+35	Ø35+70	118°	Ø200x40xØ20	Nr. 1	kW 0,55			



ART. 102 AFFILAPUNTE Ø35+70 + SMERIGLIATRICE
DRILLS SHARPENING + GRINDING M. Ø35+70
AFFÛTEUSE DE FORÈTS Ø35+70 + MEULE
SPIRALBOHRER UND SCHEIBENSCHLEIFM.

Volt 400 kW 1,8								
hp	Rpm	m/s	dB	E	F	G	G1	kg
2,5	1400 2800	15 30	70	650	1100	1300	1030	120
				OPTIONAL				
Arm B	α°	Ø mm	Nr.	Ø mm	IA-2			
Ø35+70	118°	Ø200x25xØ20	1	Ø200x40xØ20	kW 0,55			

ART. 103 AFFILAPUNTE Ø5+35 + SMUSSATRICE
DRILLS SHARP. Ø5+35 + CHAMFERING MAC.
AFFÛTEUSE DE FORÈTS Ø5+35 + CHANFR.
SPIRALBOHRERSCH.-UND KANTENFRÄSM.

Volt 400 kW 1,8								
hp	Rpm	m/s	dB	E	F	G	G1	kg
2,5	1400 2800	15 30	70	650	910	1300	1070	130
				OPTIONAL				
Ø mm	Z	P	R	T	Sm	J°		
80	10	500	80	100	0+6	15°+45°		
				OPTIONAL				
Arm A	α°	Ø mm	D-AFF	IA-1				
Ø5+35	118°	Ø200x40xØ20	Nr. 1	kW 0,55				





ART. 112 AFFILAPUNTE Ø5+35 + AFFILAUTENSILI DRILLS SHARP. Ø5+35 + TOOLS GRINDING M. AFFÛT. DE FORÈTS Ø5+35 + AFF. D'OUTILS SPIRALBOHRERSC.-UND WERKZEUGSCHL.									
Volt 400 kW 1,8									
hp	Rpm	m/s	dB	E	F	G	G1	kg	
2,5	1400 2800	15 30	70	650	1050	1300	1020	115	
Arm A	α°		Ø mm		D-AFF				
Ø5+35	118°		Ø200x40xØ20		Nr. 1				
						OPTIONAL			
A	B	J°	NONIUS		IA-2				
390	150	-45°+45°	Nr. 1		kW 0,55				



ART. 115 AFFILAUTENSILI DOPPIA DOUBLE TOOLS GRINDING MACHINE AFFÛTEUSE D'OUTILS DE TOUR 2 POSTES WERKZEUGSCHLEIFMASCHINE									
Volt 400 kW 1,8									
hp	Rpm	m/s	dB	E	F	G	G1	kg	
2,5	1400 2800	15 30	70	650	850	1200	925	110	
Ø mm		D-AFF		A	B	J°	NONIUS		
Ø200x40xØ20		Nr. 1		390	150	-45°+45°	Nr. 2		



COVER INCLUDED

ART. 114 AFFILAUTENSILI + SMERIGLIATRICE GRINDING TOOLS + GRINDING MACHINE AFFÛTEUSE D'OUTILS + TOURET A MEULE SCHEIBENSCHLEIF-UND WERKZEUGSCHLEIFM.									
Volt 400 kW 1,8									
hp	Rpm	m/s	dB	E	F	G	G1	kg	
2,5	1400 2800	15 30	70	650	800	1200	925	110	
Ø mm		Ø mm		D-AFF					
Ø200x25xØ20		Ø200x40xØ20		Nr. 1					
						OPTIONAL			
A	B	J°	NONIUS		IA-2				
390	150	-45°+45°	Nr. 1		kW 0,55				



ART. 104 AFFILAPUNTE Ø5+35 + LEVIGATRICE DRILLS SHARPENING Ø5+35 + GRINDING M. AFFÛTEUSE DE FORÈTS Ø5+35 + TANK SPIRALBOHRERSC.-UND BANDSCHLEIFM.									
Volt 400 kW 1,8									
hp	Rpm	m/s	dB	E	F	G	G1	kg	
2,5	1400 2800	10 20	72	650	950	1700	1100	140	
Arm A	α°		Ø mm		D-AFF				
Ø5+35	118°		Ø200x40xØ20		Nr. 1				
						OPTIONAL			
A	B	C	D	Ø	IA-2		SQT		
1500	120	470	120	135	kW 0,55		H=445 L=80		



ASP. 02		ASPIRATORE CENTRIFUGO CENTRIFUGAL DUST EXTRACTOR VENTILATEUR D'ASPIRATION CENTRIFUGE ABSAUGANLAGE FÜR UNTERBAUSCHRÄNKE						
Volt 400 kW 0,55								
hp	Rpm	dB	E	F	G	G1	kg	
0,75	2800	70	325	335	270	140	10	
Portata max m³/h			Pressione totale max mm H₂O					
1000			85					

ASP. 03		ASPIRATORE CON SACCO FILTRO BAG FILTER DUST EXTRACTOR ASPIRATEUR AVEC SAC STATIONÄRE ABSAUGANLAGE MIT SATUBSACK						
Volt 400 kW 0,75								
hp	Rpm	dB	E	F	G	G1	kg	
1	2800	70	650	650	1400	1075	55	
Portata max m³/h			Pressione totale max mm H₂O					
520			310					



ASP.01 HP2		ASPIRATORE A CICLONE CYCLONE DUST EXTRACTOR ASPIRATEUR CYCLONE ZYKLONABSCHIEDER						
Volt 400 kW 1,5								
hp	Rpm	dB	E	F	G	G1	kg	
2	2800	72	650	650	1550	1060	133	
Portata max m³/h			Pressione totale max mm H₂O					
940			385					

ASP.01 HP4		ASPIRATORE A CICLONE CYCLONE DUST EXTRACTOR ASPIRATEUR CYCLONE ZYKLONABSCHIEDER						
Volt 400 kW 3								
hp	Rpm	dB	E	F	G	G1	kg	
4	2800	74	750	750	1900	1325	195	
Portata max m³/h			Pressione totale max mm H₂O					
1360			485					



ASP. 04		ASPIRATORE CENTRIFUGO CON BASAMENTO BAG FILTER DUST EXTRACTOR WITH BASE VENTILATEUR D'ASPIRATION CENTRIFUGE AVEC SOCLE ABSAUGANLAGE IM UNTERSCHRANK EINGEBAUT						
Volt 400 kW 0,55								
hp	Rpm	dB	E	F	G	G1	kg	
0,75	2800	70	600	600	780	530	45	
Portata max m³/h			Pressione totale max mm H₂O					
1000			85					









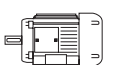

OPTIONAL
RA2B

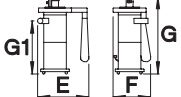

OPTIONAL
RA2B

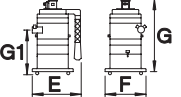

ASP. 06	ASPIRATORE AD ACQUA DUST EXTRACTOR WITH WATER ASPIRATEUR À EAU ABSAUGANLAGE MIT WASSER						
							
Volt 400 kW 0,37							
hp	Rpm	dB	E	F	G	G1	kg
0,50	2800	68	620	430	1250	880	25
Portata max m ³ /h			Pressione totale max mm H ₂ O				
800			120				

ASP. 07	ASPIRATORE AD ACQUA DUST EXTRACTOR WITH WATER ASPIRATEUR À EAU ABSAUGANLAGE MIT WASSER						
							
Volt 400 kW 1,1							
hp	Rpm	dB	E	F	G	G1	kg
1,5	2800	70	830	500	1500	930	45
Portata max m ³ /h			Pressione totale max mm H ₂ O				
1200			150				

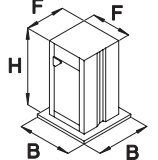
BAS. 01	BASAMENTO BASE SOCLE UNTERBAUSCHRÄNK		
			
B	F	H	kg
540	400	780	40

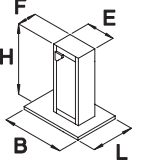
BAS. 02	BASAMENTO BASE SOCLE UNTERBAUSCHRÄNK				
					
B	L	E	F	H	kg
650	450	300	200	750	25



Video on
www.aceti.com

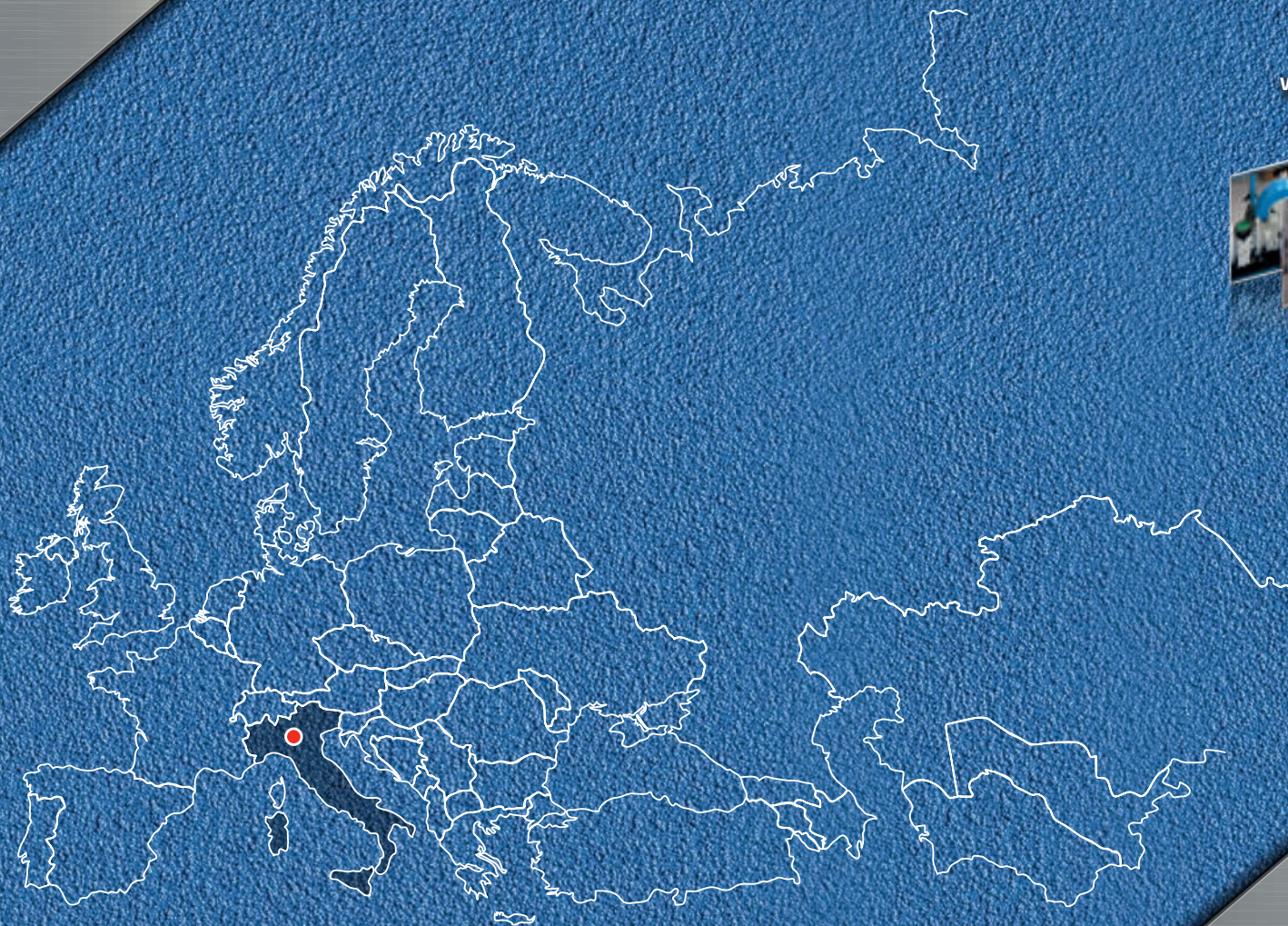

Aceti Macchine s.n.c.

24060 Bolgare (Bergamo) Italy | via ai Dossi, 32

Tel. +39 035 843 751 (r.a) | Fax +39 035 841 624

info@aceti.com | www.aceti.com